

Enerpac hydraulic cylinders are available in hundreds of different configurations. Whatever the industrial application... lifting, pushing, pulling, bending, holding... whatever the force capacity, stroke length, or size restrictions... single- or double-acting, solid or hollow plunger, you can be sure that Enerpac has the cylinder to suit your high force application. Enerpac jacking cylinders fully comply to ASME B30.1 (except BRD-Series).



With the 3rd Generation comes a trio of key features

The next evolution of the legendary Enerpac RC-Series hydraulic cylinder. The driving force of the Enerpac cylinder range, the new **RC-TRIO** is as **versatile** as ever. Featuring a new Trio Bearing System for **enhanced durability** and a hybrid spring-return system for **faster retraction** and even **greater productivity**.

System for **enhanced durability** and a hybrid spring-return system for **faster retraction** and even **greater productivity**.

NEW RC-TRIO SERIES CYLINDERS

New TRIO Bearing System

- Includes up to 4 high-performance wear bands that offer increased resistance to damage, reducing bearing load and increasing cylinder lifespan.
- Hardened composite material wear bands increase bearing surface area for greater sideload resistance - Significantly improving cylinder life.
- New high-performance Polyethylene seals last longer than ever, improving lifespan and keep you working for longer.

New TRIO Stop Ring

- Part of the Trio Bearing System, the Trio Stop Ring includes an additional wear band or high-strength bronze to absorb greater side load
- Capable of taking full cylinder extension force
- Features durable wiper to help prevent contamination from entering the cylinder during retract cycles.

New TRIO Spring System

- Hybrid pre-tensioned return springs for up to 3x faster retraction and increased productivity.
- High-strength steel wire improves spring life
- Spring retention design improves serviceability while allowing higher pre-load during assembly
- Spring is easily removed without special tools.

Durable Piston Rod

- High-strength steel plunger for improved life and sideload resistance
- Nickel-plated plunger coating improves corrosion protection
- Internal plunger threads for easy tool fixturing.

Enhanced Ergonomics

- Standard carry handles on cylinders from 15 up to 25 kg. Sizes above include certified lifting eyes or optional handles.
- Collar threads, plunger threads and base mounting holes enable easy fixturing (on most models).



Improved Saddle Retention

- Hardened plunger saddle protects plunger end during all lifting operations
- Easily removable for access to plunger mounting threads
- Tilt and smooth saddles available as accessories (compatible with new range of CATS-Series Tilt Saddles).

Enduring Compatibility

- For full compatibility and peace of mind, the new RC-Series model numbers, external dimensions and threads remain unchanged from prior RC-Series cylinders. Ensuring compatibility with historical versions and systems.



Note: The cut-away drawing is representative of typical cylinder construction, and may not represent all cylinders in this section.

Hydraulic Cylinders and Lifting Products Section Overview

Capacity ¹⁾ ton (kN)	Stroke Range (mm)	Cylinder Type and Functions	Series	Page
5 - 95 (45 - 933)	16 - 362	General Purpose Cylinders, Single-Acting Accessories: Saddles, Base Plates, Mounting Blocks, Clevis Eyes	RC A, CATS JBI, RE	6 ▶ 10 ▶
10 - 150 (63 - 1589)	50 - 250	Aluminium Cylinders, Single-Acting, Lock Nut, Hollow Plunger	RAC RACL RACH	12 ▶ 14 ▶ 16 ▶
20 - 150 (229 - 1589)	50 - 250	Aluminium Cylinders, Double-Acting Hollow Plunger & Solid Plunger	RARH RAR	18 ▶ 20 ▶
10 - 1000 (97 - 10.165)	6 - 17	Ultra-Flat Cylinders, Single-Acting, Load Return, with Stop Ring or Tilting Function	CULP CUSP	22 ▶ 23 ▶
60 - 500 (606 - 5114)	45 - 50	Low-Height Lock Nut Cylinders Single-Acting, Load Return	LPL	24 ▶
5 - 150 (45 - 1386)	6 - 62	Low-Height Cylinders, Single-Acting or spring-return	RSM RCS	26 ▶
4 - 74 (43 - 727)	17 - 600	Low-Height Telescopic Cylinders Multi-Stage Telescopic Cylinders	RLT RT	28 ▶ 30 ▶
2,5 - 50 (24 - 506)	127 - 154	Pull Cylinders, Single-Acting, Spring Return	BRC BRP	32 ▶
12 - 145 (125 - 1429)	8 - 258	Hollow Plunger Cylinders, Single- and Double-Acting	RCH RRH	34 ▶ 36 ▶
4 - 23 (35 - 222)	28 - 260	Precision Production Cylinders, Double-Acting (including Mounting Attachments)	BRD	38 ▶
10 - 520 (101 - 5108)	16 - 1219	Long Stroke Cylinders, Double-Acting	RR	40 ▶
50 - 1000 (550 - 10.644)	50 - 300	High Tonnage Cylinders, Single- and Double-Acting	HCG HCR	48 ▶ 52 ▶
50 - 1000 (550 - 10.644)	50 - 300	High Tonnage Lock Nut Cylinders, Single- and Double-Acting	HCL HCRL	56 ▶ 60 ▶
1 - 95 (8,9 - 933)	11 - 362	Cylinder - Pump Sets, Single-Acting Extreme Environment Products Power Box – Portable Tool Sets	SC RC, P, V SL, SR, SW	62 ▶ 64 ▶ 65 ▶
2 - 100 (20 - 980)	62 - 460	Aluminium and Steel Jacks Industrial Steel Bottle Jacks	JH, JHA GBJ	66 ▶ 67 ▶
54 - 181 (533 - 1778)	356 - 686	POW'R-RISER® Mobile Lifting Jacks POW'R-LOCK™ Mobile Lift System	PR PL	68 ▶ 70 ▶

¹⁾ All ton values specified in this catalogue are approximate and for cylinder class identification only. Please refer to the kN data for calculations.

▼ From left to right: RC2510, RC53, RC1002, RC108, RC5010, RC156



- Trio Bearing system with hardened composite wear bands for optimal side load resistance
- Strengthened Trio Stop Ring improves durability and side load resistance
- Trio Hybrid pre-tensioned spring system provides faster retraction
- High-grade polyethylene seals for low wear and long service life
- Plunger wiper reduces contamination, extending cylinder life.
- Collar and plunger threads and base mounting holes enable easy fixturing (on most models)
- Standard certified lifting eyes on cylinder models above 25 kg weight. Interchangeable with optional CHM6 carrying handle
- Designed for use in all positions
- Baked enamel finish for increased corrosion resistance
- Includes CR400 coupler, dust cap and collar thread protector
- RC-Series model numbers, external dimensions and threads remain unchanged from prior RC-Series cylinders

▼ *Foundation repair: to re-stabilize the foundation, the 308 ton silo needed to be lifted, levelled and structurally supported. 25 ton RC-Series hydraulic jacks were attached to a bracket on the top of each steel pier. Powered by a Z-Class pump, the hydraulic jacks applied 20 ton of force at each placement to lift the silo 5,1 cm.*



The Industry Standard General Purpose Cylinder



Saddles

All RC cylinders (except RC50 and RC101) have a hardened removable grooved saddle. For tilt and flat saddles, see the RC-Series accessory page. All CATS-Series Tilt Saddles use a nitrocarburization surface treatment for improved corrosion protection.

Page: 10



Base Plates

To ensure the stability of cylinders for lifting applications, base plates are available for 10, 25 and 50 ton RC cylinders.

Page: 10



Specialty Attachments

For solving all kinds of application problems, specialty attachments are available for 5, 10 and 25 ton RC cylinders.

Page: 182

▼ *Synchronous lifting set-up for 200 ton petrochemical process module using twelve RC2510 cylinders. To ensure the stability of the cylinders JBI25 base plates are installed.*



Single-Acting, General Purpose Cylinders



Optional Carrying Handle CHM6

Standard certified lifting eyes on cylinder models above 25 kg weight (RC5010 and heavier models). Interchangeable with optional carrying handle. Order model number **CHM6**.

▼ **QUICK SELECTION CHART** For complete technical information see next page.

Cylinder Capacity	Stroke	Model Number	Cylinder Effective Area	Oil Capacity	Collapsed Height	
ton (kN)	(mm)		(cm ²)	(cm ³)	(mm)	(kg)
5 (45)	16	RC50	6,4	10	41	1,0
	25	RC51	6,4	16	110	1,0
	79	RC53	6,4	50	165	1,5
	127	RC55 *	6,4	83	216	1,9
	177	RC57	6,4	115	273	2,4
	232	RC59	6,4	151	324	2,8
10 (101)	26	RC101	14,4	38	90	1,8
	54	RC102 *	14,4	78	121	2,3
	105	RC104	14,4	152	171	3,3
	156	RC106 *	14,4	226	248	4,4
	203	RC108	14,4	294	298	5,4
	257	RC1010 *	14,4	373	349	6,4
	304	RC1012	14,4	441	400	6,8
	356	RC1014	14,4	516	451	8,2
15 (142)	25	RC151	20,3	51	124	3,3
	51	RC152	20,3	104	149	4,1
	101	RC154 *	20,3	205	200	5,0
	152	RC156 *	20,3	308	271	6,8
	203	RC158	20,3	411	322	8,2
	254	RC1510	20,3	516	373	9,5
	305	RC1512	20,3	619	424	10,9
	356	RC1514	20,3	723	475	11,8
25 (232)	26	RC251	33,3	86	140	5,9
	50	RC252 *	33,3	166	165	6,4
	102	RC254 *	33,3	339	216	8,2
	158	RC256 *	33,3	525	273	10,0
	210	RC258	33,3	697	324	12,2
	261	RC2510	33,3	867	375	14,1
	311	RC2512	33,3	1033	425	16,3
	362	RC2514 *	33,3	1202	476	17,7
30 (295)	209	RC308	42,9	880	387	18,1
50 (498)	51	RC502	71,3	362	176	15,0
	101	RC504	71,3	719	227	19,1
	159	RC506 *	71,3	1131	283	23,1
	260	RC5010	71,3	1855	384	31,8
	337	RC5013	71,3	2399	460	37,6
75 (718)	156	RC756	102,6	1601	286	29,5
	333	RC7513	102,6	3417	492	59,0
95 (933)	50	RC1002	133,1	676	219	36,7
	168	RC1006	133,1	2239	357	59,0
	260	RC10010	133,1	3466	449	72,6

* Available as set, see note on this page.

RC-Trio Series



Capacity:
5 - 95 ton

Stroke:
16 - 362 mm

Maximum Operating Pressure:
700 bar



Think Safety

Manufacturer's rating of load and stroke are maximum safe limits. Good practice encourages using only 80% of these ratings.

Page: **406**



Lightweight Aluminium Cylinders

If you need a higher cylinder capacity-to-weight-ratio the **RAC-Series** are the perfect choice.

Page: **13**



Gauges

Minimize the risk of overloading and ensure long, dependable service from your equipment. Refer to the System Components

Section for a full range of gauges.

Page: **127**

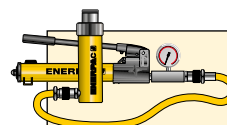

Cylinder-Pump Sets

All cylinders marked with an * are available as **sets** (cylinder, gauge, couplers, hose and pump) for your ordering convenience.

Page: **62**

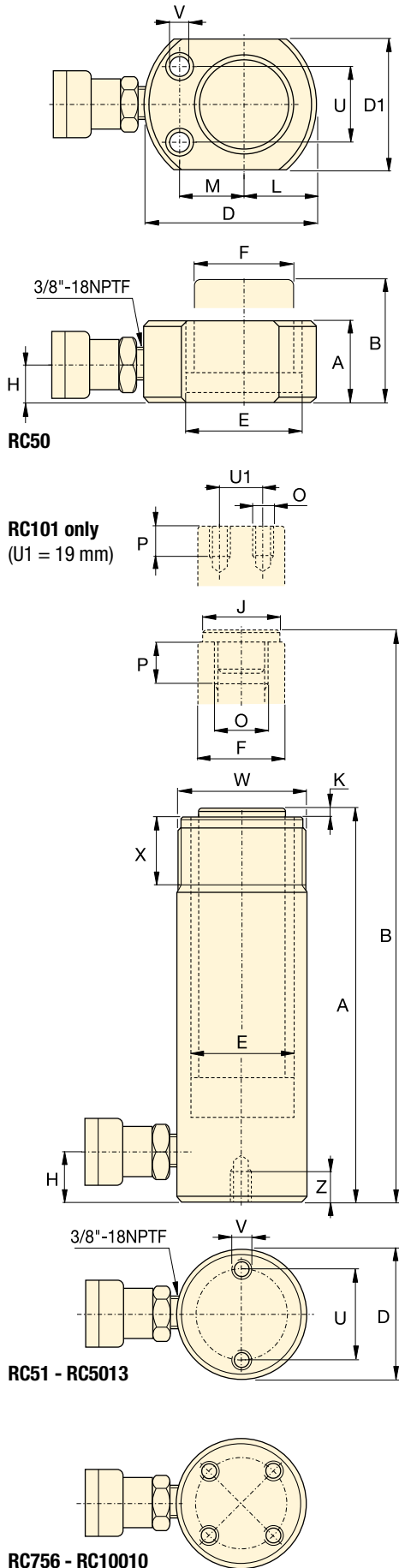

Speed Chart and Pump Selection Tool

See the Enerpac Cylinder Speed Chart in our 'Yellow Pages' to determine your approximate cylinder speed. See Pump Selection Tool on website for help to choose the most suitable pump for your application.

Page: **415**

◀ For full features see previous page.

Cylinder Capacity	Stroke	Model Number	Cylinder Effective Area	Oil Capacity	Collapsed Height	Extended Height	Outside Dia.
ton (kN)	(mm)		(cm ²)	(cm ³)	A (mm)	B (mm)	D (mm)
5 (45)	16	RC50 ²⁾	6,4	10	41	57	58 ³⁾
	25	RC51	6,4	16	110	135	38
	79	RC53	6,4	50	165	244	38
	127	RC55 ¹⁾	6,4	83	216	343	38
	177	RC57	6,4	115	273	450	38
	232	RC59	6,4	151	324	556	38
10 (101)	26	RC101 ⁴⁾	14,4	38	90	116	57
	54	RC102 ¹⁾	14,4	78	121	175	57
	105	RC104	14,4	152	171	276	57
	156	RC106 ¹⁾	14,4	226	248	404	57
	203	RC108	14,4	294	298	501	57
	257	RC1010 ¹⁾	14,4	373	349	606	57
	304	RC1012	14,4	441	400	704	57
	356	RC1014	14,4	516	451	807	57
15 (142)	25	RC151	20,3	51	124	149	70
	51	RC152	20,3	104	149	200	70
	101	RC154 ¹⁾	20,3	205	200	301	70
	152	RC156 ¹⁾	20,3	308	271	423	70
	203	RC158	20,3	411	322	525	70
	254	RC1510	20,3	516	373	627	70
	305	RC1512	20,3	619	424	729	70
	356	RC1514	20,3	723	475	831	70
25 (232)	26	RC251	33,3	86	140	166	86
	50	RC252 ¹⁾	33,3	166	165	215	86
	102	RC254 ¹⁾	33,3	339	216	318	86
	158	RC256 ¹⁾	33,3	525	273	431	86
	210	RC258	33,3	697	324	534	86
	261	RC2510	33,3	867	375	636	86
	311	RC2512	33,3	1033	425	736	86
	362	RC2514 ¹⁾	33,3	1202	476	838	86
30 (295)	209	RC308	42,9	880	387	596	102
50 (498)	51	RC502	71,3	362	176	227	127
	101	RC504	71,3	719	227	328	127
	159	RC506 ¹⁾	71,3	1131	283	442	127
	260	RC5010	71,3	1855	384	644	127
	337	RC5013	71,3	2399	460	797	127
75 (718)	156	RC756	102,6	1601	286	442	146
	333	RC7513	102,6	3417	492	825	146
95 (933)	51	RC1002	133,1	676	219	270	178
	168	RC1006	133,1	2239	357	525	178
	260	RC10010	133,1	3466	449	709	178

¹⁾ Available as set, see note on page 7.

²⁾ RC50 cylinder has a non removable grooved saddle and no collar thread.

³⁾ RC50: D1 = 41 mm, L = 20 mm, M = 25 mm.

⁴⁾ RC101 has plunger with two thread holes and non-removable saddle.

Single-Acting, General Purpose Cylinders

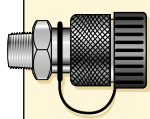

Couplers Included!

CR-400 couplers included on all models. Fits all HC-Series hoses.

Capacity:

5 - 95 ton

Stroke:

16 - 362 mm

Maximum Operating Pressure:

700 bar

RC-Trio Series



Cylinder Bore Dia. E (mm)	Plunger Dia. F (mm)	Base to Adv. Port H (mm)	Saddle Dia. J (mm)	Saddle Protr. from Plgr. K (mm)	Plunger Internal Thread O	Plunger Thread Length P (mm)	Base Mounting Holes			Collar Thread W	Collar Thread Length X (mm)	 (kg)	Model Number
							Bolt Circle U (mm)	Thread V	Thd. Depth Z (mm)				
28,6	25,4	19	2)	2)	2)	2)	29	5,6 mm	—	—	—	1,0	RC50 ²⁾
28,6	25,4	19	25	6	3/4" - 16 UN	14	25	1/4" - 20 UNC	14	1 1/2" - 16 UN	28	1,0	RC51
28,6	25,4	19	25	6	3/4" - 16 UN	14	25	1/4" - 20 UNC	14	1 1/2" - 16 UN	28	1,5	RC53
28,6	25,4	19	25	6	3/4" - 16 UN	14	25	1/4" - 20 UNC	14	1 1/2" - 16 UN	28	1,9	RC55 ¹⁾
28,6	25,4	19	25	6	3/4" - 16 UN	16	25	1/4" - 20 UNC	14	1 1/2" - 16 UN	28	2,4	RC57
28,6	25,4	19	25	6	3/4" - 16 UN	16	25	1/4" - 20 UNC	14	1 1/2" - 16 UN	28	2,8	RC59
42,8	38,1	19	—	—	#10 - 24 UN	6	40	5/16" - 18 UNC	12	2 1/4" - 14 UN	27	1,8	RC101 ⁴⁾
42,8	38,1	19	35	6	1" - 8 UN	19	40	5/16" - 18 UNC	12	2 1/4" - 14 UN	27	2,3	RC102 ¹⁾
42,8	38,1	19	35	6	1" - 8 UN	19	40	5/16" - 18 UNC	12	2 1/4" - 14 UN	27	3,3	RC104
42,8	38,1	19	35	6	1" - 8 UN	19	40	5/16" - 18 UNC	12	2 1/4" - 14 UN	27	4,4	RC106 ¹⁾
42,8	38,1	19	35	6	1" - 8 UN	19	40	5/16" - 18 UNC	12	2 1/4" - 14 UN	27	5,4	RC108
42,8	38,1	19	35	6	1" - 8 UN	19	40	5/16" - 18 UNC	12	2 1/4" - 14 UN	27	6,4	RC1010 ¹⁾
42,8	38,1	19	35	6	1" - 8 UN	19	40	5/16" - 18 UNC	12	2 1/4" - 14 UN	27	6,8	RC1012
42,8	38,1	19	35	6	1" - 8 UN	19	40	5/16" - 18 UNC	12	2 1/4" - 14 UN	27	8,2	RC1014
50,8	41,3	19	38	9	1" - 8 UN	25	48	3/8" - 16 UNC	12	2 3/4" - 16 UN	30	3,3	RC151
50,8	41,3	19	38	9	1" - 8 UN	25	48	3/8" - 16 UNC	12	2 3/4" - 16 UN	30	4,1	RC152
50,8	41,3	19	38	9	1" - 8 UN	25	48	3/8" - 16 UNC	12	2 3/4" - 16 UN	30	5,0	RC154 ¹⁾
50,8	41,3	25	38	9	1" - 8 UN	25	48	3/8" - 16 UNC	12	2 3/4" - 16 UN	30	6,8	RC156 ¹⁾
50,8	41,3	25	38	9	1" - 8 UN	25	48	3/8" - 16 UNC	12	2 3/4" - 16 UN	30	8,2	RC158
50,8	41,3	25	38	9	1" - 8 UN	25	48	3/8" - 16 UNC	12	2 3/4" - 16 UN	30	9,5	RC1510
50,8	41,3	25	38	9	1" - 8 UN	25	48	3/8" - 16 UNC	12	2 3/4" - 16 UN	30	10,9	RC1512
50,8	41,3	25	38	9	1" - 8 UN	25	48	3/8" - 16 UNC	12	2 3/4" - 16 UN	30	11,8	RC1514
65,1	57,2	25	51	10	1 1/2" - 16 UN	25	59	1/2" - 13 UNC	19	3 5/16" - 12 UN	49	5,9	RC251
65,1	57,2	25	51	10	1 1/2" - 16 UN	25	59	1/2" - 13 UNC	19	3 5/16" - 12 UN	49	6,4	RC252 ¹⁾
65,1	57,2	25	51	10	1 1/2" - 16 UN	25	59	1/2" - 13 UNC	19	3 5/16" - 12 UN	49	8,2	RC254 ¹⁾
65,1	57,2	25	51	10	1 1/2" - 16 UN	25	59	1/2" - 13 UNC	19	3 5/16" - 12 UN	49	10,0	RC256 ¹⁾
65,1	57,2	25	51	10	1 1/2" - 16 UN	25	59	1/2" - 13 UNC	19	3 5/16" - 12 UN	49	12,2	RC258
65,1	57,2	25	51	10	1 1/2" - 16 UN	25	59	1/2" - 13 UNC	19	3 5/16" - 12 UN	49	14,1	RC2510
65,1	57,2	25	51	10	1 1/2" - 16 UN	25	59	1/2" - 13 UNC	19	3 5/16" - 12 UN	49	16,3	RC2512
65,1	57,2	25	51	10	1 1/2" - 16 UN	25	59	1/2" - 13 UNC	19	3 5/16" - 12 UN	49	17,7	RC2514 ¹⁾
73,0	57,2	29	51	10	1 1/2" - 16 UN	25	59	1/2" - 13 UNC	16	3 5/16" - 12 UN	49	18,1	RC308
95,2	79,4	33	71	2	—	—	95	1/2" - 13 UNC	19	5" - 12 UN	55	15,0	RC502
95,2	79,4	33	71	2	—	—	95	1/2" - 13 UNC	19	5" - 12 UN	55	19,1	RC504
95,2	79,4	35	71	2	—	—	95	1/2" - 13 UNC	19	5" - 12 UN	55	23,1	RC506 ¹⁾
95,2	79,4	35	71	2	—	—	95	1/2" - 13 UNC	19	5" - 12 UN	55	31,8	RC5010
95,2	79,4	35	71	2	—	—	95	1/2" - 13 UNC	19	5" - 12 UN	55	37,6	RC5013
114,3	95,3	30	71	2	—	—	114	5/8" - 13 UNC	16	5 3/4" - 12 UN	44	29,5	RC756
114,3	95,3	30	71	2	—	—	114	5/8" - 13 UNC	16	5 3/4" - 12 UN	44	59,0	RC7513
130,2	104,8	41	71	2	—	—	140	3/4" - 10 UNC	25	6 7/8" - 12 UN	44	36,7	RC1002
130,2	104,8	41	71	2	—	—	140	3/4" - 10 UNC	25	6 7/8" - 12 UN	44	59,0	RC1006
130,2	104,8	41	71	2	—	—	140	3/4" - 10 UNC	25	6 7/8" - 12 UN	44	72,6	RC10010

SELECTION CHART

For use with Cylinder Capacity ton (kN)	Saddles			Base Plate	Mounting Block	Clevis Eyes	
	Flat	Grooved ¹⁾	Tilt			Base ⁴⁾	Plunger
5 (45)	A53F ²⁾	A53G ²⁾	-	-	RB5 ²⁾ , AW51 ²⁾ , AW53 ²⁾	REB5 ²⁾	REP5 ²⁾
10 (101)	A12 ³⁾ , A102F ³⁾	A102G ³⁾	CATS12 ³⁾	JB110 ³⁾	RB10, AW102	REB10	REP10 ³⁾
15 (142)	-	A152G	CATS12	-	RB15	REB15	REP10
25 (232)	A29 ⁵⁾	A252G	CATS52	JB125	RB25	REB25	REP25
30 (295)	A29 ⁵⁾	A252G	CATS52	-	RB25	-	REP25
50 (498)	-	-	CATS100	JB150	-	-	-
75 (718)	-	-	CATS100	-	-	-	-
95 (933)	-	-	CATS100	-	-	-	-

¹⁾ Standard on 5-30 ton RC-cylinders ²⁾ Except RC50 ³⁾ Except RC101 ⁴⁾ Mounting screws are included. ⁵⁾ Used with Bender Sets.

DIMENSION CHARTS

Model Number	Saddle Dimensions (mm)			A53F, A102F A12, A29	For Cylinder Capacity ton (kN)	Tilt Saddle Model Number	Addition to Collapsed Height A1 (mm)	Saddle Diameter J1 (mm)	
	A	B	C						
Flat					10 (101)	CATS12	14	35	
A53F	25	6	17	15 (142)	CATS12	11	35		
A102F	35	6	22	25 (232)	CATS52	15	50		
A12	51	48	1"-8 UNC	30 (295)	CATS52	15	50		
Grooved					50 (498)	CATS100	15	71	
A53G	25	6	17	75 (718)	CATS100	15	71		
A102G	35	6	22	95 (933)	CATS100	15	71		
A152G	38	9	22						
A252G	50	9	35						

Model Number	Base Plate Dimensions (mm)						
	A	B	C	D	E		
JB110	228	228	135	58	20		
JB125	279	279	140	86	26		
JB150	304	15	95	131	31		

Model Number	Mounting Block Dimensions (mm)											
	A	B	C	D	E	F	G	H				
RB5	1 1/2" -16UN	88	76	-	25	-	-	-				
AW51	1 1/2" -16UN	70	59	10	24	54	1/4" -16 UN	41				
AW53	1 1/2" -16UN	72	7	7	19	57	1/4" -20 UN	10				
RB10	2 1/4" -14UN	114	88	-	25	-	-	-				
AW102	2 1/4" -14UN	100	82	16	30	76	7/16" -20 UN	58				
RB15	2 3/4" -16UN	101	114	-	38	-	-	-				
RB25	3 5/16" -12UN	127	165	-	50	-	-	-				

Type	Model Number	Clevis Eye Dimensions (mm)						Pin-to-Pin * (mm)		
		A	B	C	D	E	F			
Base ⁴⁾	REB5	44	47	14	16	16	25	60,2		
	REB10	63	66	25	22	25	35	78,0		
	REB15	76	66	25	22	25	35	78,0		
	REB25	95	79	38	31	31	41	87,6		
Plunger	REP5	28	45	14	16	16	19	-		
	REP10	42	61	25	22	25	28	-		
	REP25	57	71	38	31	31	35	-		

⁴⁾ Mounting screws are included.

* Pin to Pin – REB and REP Clevises fitted. Add cylinder collapsed height.

The Enerpac Lightweight Aluminium Cylinders

▼ From left to right: RAC, RACL, RACH, RAR



- **Lightweight, easy to carry and position to allow a higher cylinder capacity-to-weight-ratio**
- **Non-corrosive by design, aluminium has always been a good material for use in many caustic environments**
- **Composite Bearings on all moving surfaces guarantee no metal-to-metal contact, to resist side loads and increase cylinder life.**

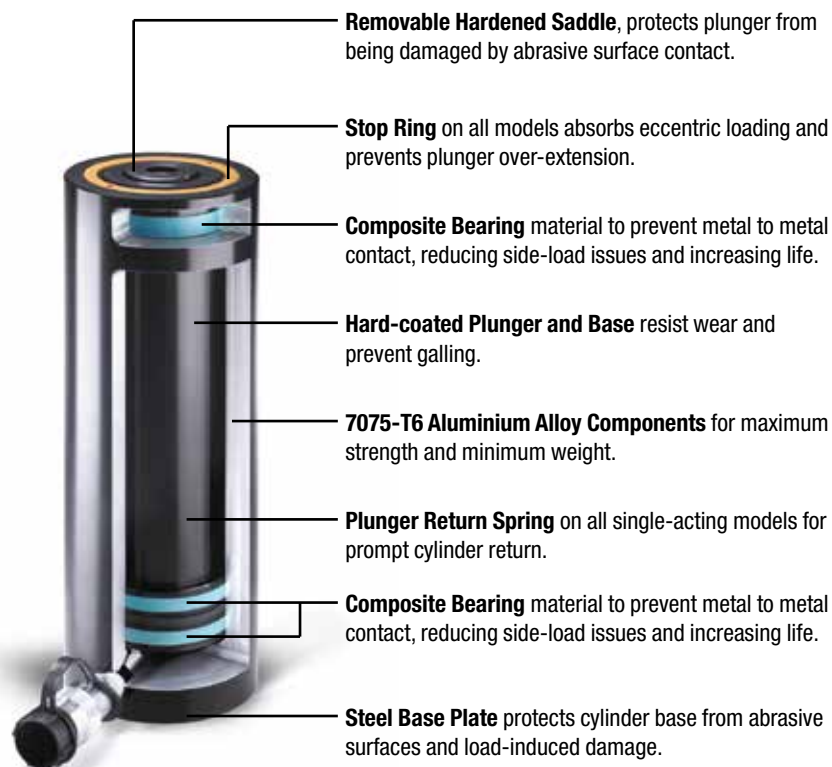

RA Series

Capacity:
10 - 150 ton

Stroke:
50 - 250 mm

Maximum Operating Pressure:
700 bar



Think Safety

Manufacturer's rating of load and stroke are maximum safe limits.

Good practice encourages using only 80% of these ratings.

Page: 406



Aluminium versus Steel

Aluminium cylinders, while offering the most lightweight solution, also have some unique limitations due to material properties. It differs from steel in that it has a lower finite fatigue life. Aluminium cylinders should NOT be used in high-cycle applications such as production.

The Enerpac line of aluminium cylinders are designed to provide 5000 cycles at their recommended pressure. **This limit should not be exceeded.** In normal lifting and many maintenance applications, this should provide a lifetime of use.



Steel Base Plate

The steel base plate protects the cylinder from damage, it should not be removed.

The base holes in these aluminium cylinders are designed for securing the steel base plate. They will not withstand the capacity of the cylinder.

Do not use the base holes in these aluminium cylinders to attach any device to the cylinder.

▼ Shown from left to right: RAC5010, RAC15010, RAC304, RAC208



Lightweight for Maximum Portability



Saddles

All RAC-cylinders are equipped with bolt-on removable hardened steel saddles. For Tilt Saddles see next page.

Page: 13



Lightweight Hand Pumps

The Enerpac composite lightweight hand pumps P392 or P802 make the optimal lightweight set.

Page: 76

- Composite bearings prevent metal-to-metal contact, increasing cylinder life and resistance to side-loads of up to 10%
- Hard-Coat finish on all surfaces resists damage and extends cylinder life
- Handles included on all 30 - 150 ton models
- For protection against load-induced damage a saddle is standard on all models
- Steel base plate is standard on RAC 20 ton models and above. The steel base plate is optional only on RAC10 and 15 ton models
- Integral stop ring prevents plunger over-travel and is capable of withstanding the full cylinder capacity
- High strength return spring for rapid cylinder retraction
- CR400 coupler and dustcap included on all models
- All cylinders meet ASME B-30.1 standard.

Cylinder Capacity at 700 bar ton (kN)	Stroke (mm)	Model Number	Cylinder Effective Area (cm ²)
10 (88)	50	RAC102	12,6
	100	RAC104	12,6
	150	RAC106	12,6
15 (137)	50	RAC152	19,6
	100	RAC154	19,6
	150	RAC156	19,6
20 (218)	50	RAC202	31,2
	100	RAC204	31,2
	150	RAC206	31,2
	200	RAC208	31,2
	250	RAC2010	31,2
30 (309)	50	RAC302	44,2
	100	RAC304	44,2
	150	RAC306	44,2
	200	RAC308	44,2
	250	RAC3010	44,2
50 (496)	50	RAC502	70,9
	100	RAC504	70,9
	150	RAC506	70,9
	200	RAC508	70,9
	250	RAC5010	70,9
100 (1002)	50	RAC1002	143,1
	100	RAC1004	143,1
	150	RAC1006	143,1
	200	RAC1008	143,1
	250	RAC10010	143,1
150 (1589)	50	RAC1502	227,0
	100	RAC1504	227,0
	150	RAC1506	227,0
	200	RAC1508	227,0
	250	RAC15010	227,0



◀ The unique Enerpac RA-Series cylinders – lightweight and made of aluminium alloy – these RAC506 cylinders are ideal for the positioning of tunnel elements under the river (High Speed Train Line, The Netherlands).

Single-Acting, Aluminium Cylinders

Optional Bolt-on Tilt Saddle Dimensions (mm)			
For Cylinder Model / Capacity ton	Tilt Saddle * Model Number	Tilt Saddle Diameter	Addition to Collapsed Height A1
RAC20, 30	CATS30	55	11
RAC50	CATS50	71	14
RAC100	CATS150	97	19
RAC150	CATS200	126	18

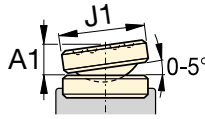

* Tilt saddles not available for 10 and 15 ton models

Optional Steel Base Plate	
For Cylinder Model / Capacity ton	Base Plate ²⁾ Model Number
RAC10	JBA10
RAC15	JBA15

²⁾ Base plate height of 6mm included on all 20-150 ton models. Base Plate is optional on 10-15 ton cylinders.

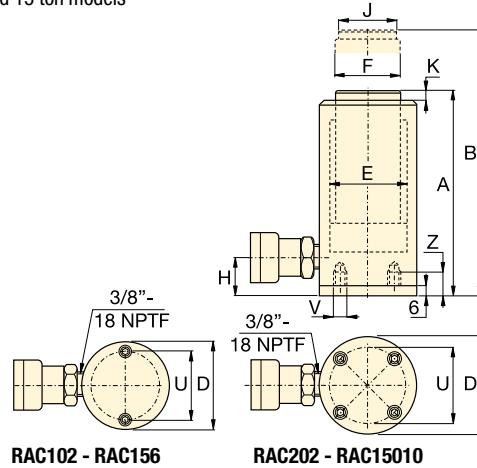

RAC102 - RAC156

RAC202 - RAC15010

RAC Series



Capacity:

10 - 150 ton

Stroke:

50 - 250 mm

Maximum Operating Pressure:

700 bar



Steel Base Plate

The steel base plate protects the cylinder from damage, it should not be removed. See warning on page 11.

Oil Capacity (cm ³)	Collapsed Height A (mm)	Extended Height B (mm)	Outside Diameter D (mm)	Cylinder Bore Diameter E (mm)	Plunger Diameter F (mm)	Bottom to Advance Port H (mm)	Saddle Diameter J (mm)	Saddle Protrusion from Plunger K (mm)	Bolt Circle U (mm)	Thread V (mm)	Thread Depth Z (mm)	Weight (kg)	Model Number
60	154	201	58	40	32	23	24	3	39	M6	12	1,3	RAC102
130	204	304	58	40	32	23	24	3	39	M6	12	1,7	RAC104
190	254	404	58	40	32	23	24	3	39	M6	12	2,0	RAC106
100	161	211	70	50	40	23	29	3	48	M6	12	1,9	RAC152
200	211	311	70	50	40	23	29	3	48	M6	12	2,4	RAC154
290	261	411	70	50	40	23	29	3	48	M6	12	2,9	RAC156
156	174	224	85	63	50	27	40	3	70	M6	12	3,6	RAC202
312	224	324	85	63	50	27	40	3	70	M6	12	4,1	RAC204
468	274	424	85	63	50	27	40	3	70	M6	12	4,6	RAC206
624	324	524	85	63	50	27	40	3	70	M6	12	5,1	RAC208
780	374	624	85	63	50	27	40	3	70	M6	12	5,6	RAC2010
221	181	231	100	75	60	32	40	3	80	M6	12	4,5	RAC302
442	231	331	100	75	60	32	40	3	80	M6	12	5,2	RAC304
663	281	431	100	75	60	32	40	3	80	M6	12	5,9	RAC306
884	331	531	100	75	60	32	40	3	80	M6	12	6,6	RAC308
1105	381	631	100	75	60	32	40	3	80	M6	12	7,3	RAC3010
354	186	236	130	95	80	30	50	3	110	M6	12	8,5	RAC502
709	236	336	130	95	80	30	50	3	110	M6	12	9,8	RAC504
1063	286	436	130	95	80	30	50	3	110	M6	12	11,1	RAC506
1417	336	536	130	95	80	30	50	3	110	M6	12	12,4	RAC508
1771	386	636	130	95	80	30	50	3	110	M6	12	13,7	RAC5010
715	221	271	180	135	110	46	94	3	150	M10	12	17,3	RAC1002
1431	271	371	180	135	110	46	94	3	150	M10	12	19,6	RAC1004
2147	321	471	180	135	110	46	94	3	150	M10	12	21,9	RAC1006
2863	371	571	180	135	110	46	94	3	150	M10	12	24,2	RAC1008
3578	421	671	180	135	110	46	94	3	150	M10	12	26,5	RAC10010
1135	243	293	230	170	140	51	113	3	200	M10	12	25,3	RAC1502
2270	293	393	230	170	140	51	113	3	200	M10	12	29,3	RAC1504
3405	343	493	230	170	140	51	113	3	200	M10	12	33,3	RAC1506
4540	393	593	230	170	140	51	113	3	200	M10	12	37,3	RAC1508
5675	443	693	230	170	140	51	113	3	200	M10	12	41,3	RAC15010

▼ Shown from left to right: RACL1006, RACL504, RACL5010



- Aluminium Lock Nut provides mechanical load holding for extended periods
- Hardened steel stop ring increasing cylinder life and resistance to side-loads of up to 5%
- Hard-Coat finish on all surfaces resists damage and extends cylinder life
- Composite bearings increase cylinder life and side load resistance
- Handles included on all models
- Steel base plate and saddle for protection against load-induced damage
- Integral stop ring prevents plunger over-travel and is capable of withstanding the full cylinder capacity
- High strength return spring for rapid cylinder retraction
- CR400 coupler and dustcap included on all models
- All cylinders meet ASME B-30.1 standards.



◀ The portable lock nut cylinder RACL1506 used for extended load supports during epoxy injection for bridge reinforcement.



Saddles

All RACL-cylinders are equipped with bolt-on removable hardened steel saddles. For Tilt Saddles see next page.

Page: 15



Hoses

Enerpac offers a complete line of high quality hydraulic hoses. To ensure the integrity of your system, specify only Enerpac hydraulic hoses.

Page: 128

Cylinder Capacity @ 700 bar ton (kN)	Stroke (mm)	Model Number	Cylinder Effective Area (cm ²)
20 (218)	50	RACL202	31,2
	100	RACL204	31,2
	150	RACL206	31,2
	200	RACL208	31,2
	250	RACL2010	31,2
30 (309)	50	RACL302	44,2
	100	RACL304	44,2
	150	RACL306	44,2
	200	RACL308	44,2
	250	RACL3010	44,2
50 (496)	50	RACL502	70,9
	100	RACL504	70,9
	150	RACL506	70,9
	200	RACL508	70,9
	250	RACL5010	70,9
100 (1002)	50	RACL1002	143,1
	100	RACL1004	143,1
	150	RACL1006	143,1
	200	RACL1008	143,1
	250	RACL10010	143,1
150 (1589)	50	RACL1502	227,0
	100	RACL1504	227,0
	150	RACL1506	227,0
	200	RACL1508	227,0
	250	RACL15010	227,0

Single-Acting, Aluminium Lock Nut Cylinders

Optional Bolt-on Tilt Saddle Dimensions (mm)			
For Cylinder Model / Capacity ton	Tilt Saddle Model Number	Tilt Saddle Diameter	Addition to Collapsed Height A1
		J1	A1
RACL20, 30	CATS30	55	11
RACL50	CATS50	71	14
RACL100	CATS150	97	19
RACL150	CATS200	126	18

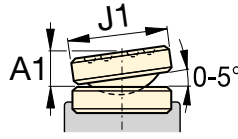

Steel Base Plate Mounting Holes			
Cylinder Model / Capacity ton	Bolt Circle U (mm)	Thread V (mm)	Thread Depth ¹⁾ Z (mm)
RACL20	70	M6	12
RACL30	80	M6	12
RACL50	110	M6	12
RACL100	150	M10	12
RACL150	200	M10	12

¹⁾ Including Base Plate Height of 6 mm and four (4) base plate bolts M6.

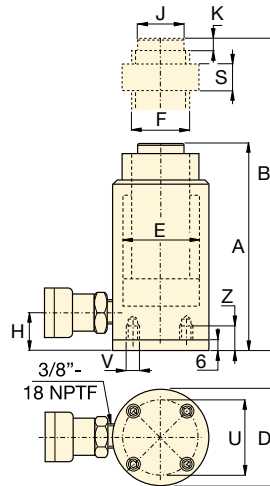

RACL Series



Capacity:

20 - 150 ton

Stroke:

50 - 250 mm

Maximum Operating Pressure:

700 bar

Oil Capacity (cm ³)	Collapsed Height A (mm)	Extended Height B (mm)	Outside Diameter D (mm)	Cylinder Bore Diameter E (mm)	Plunger Diameter (Threaded) F (mm)	Bottom to Advance Port H (mm)	Saddle Diameter J (mm)	Saddle Protrusion from Plunger K (mm)	Lock Nut Height S (mm)	Weight (kg)	Model Number
156	224	274	85	63	Tr 55 x 4	27	40	3	50	4,0	RACL202
312	274	374	85	63	Tr 55 x 4	27	40	3	50	4,6	RACL204
468	324	474	85	63	Tr 55 x 4	27	40	3	50	5,2	RACL206
624	374	574	85	63	Tr 55 x 4	27	40	3	50	5,8	RACL208
780	424	674	85	63	Tr 55 x 4	27	40	3	50	6,4	RACL2010
221	231	281	100	75	Tr 60 x 4	33	40	3	50	5,4	RACL302
442	281	381	100	75	Tr 60 x 4	33	40	3	50	6,1	RACL304
663	331	481	100	75	Tr 60 x 4	33	40	3	50	6,8	RACL306
883	381	581	100	75	Tr 60 x 4	33	40	3	50	7,5	RACL308
1105	431	681	100	75	Tr 60 x 4	33	40	3	50	8,2	RACL3010
354	236	286	130	95	Tr 80 x 4	30	50	3	50	9,3	RACL502
709	286	386	130	95	Tr 80 x 4	30	50	3	50	10,6	RACL504
1063	336	486	130	95	Tr 80 x 4	30	50	3	50	12,6	RACL506
1417	386	586	130	95	Tr 80 x 4	30	50	3	50	13,2	RACL508
1771	436	686	130	95	Tr 80 x 4	30	50	3	50	14,5	RACL5010
716	296	346	180	135	Tr 110 x 6	46	94	3	75	21,9	RACL1002
1431	346	446	180	135	Tr 110 x 6	46	94	3	75	24,2	RACL1004
2147	396	546	180	135	Tr 110 x 6	46	94	3	75	26,5	RACL1006
2863	446	646	180	135	Tr 110 x 6	46	94	3	75	28,8	RACL1008
3578	496	746	180	135	Tr 110 x 6	46	94	3	75	31,1	RACL10010
1135	323	373	230	170	Tr 140 x 6	51	113	3	80	32,2	RACL1502
2270	373	473	230	170	Tr 140 x 6	51	113	3	80	36,2	RACL1504
3405	423	573	230	170	Tr 140 x 6	51	113	3	80	40,2	RACL1506
4540	473	673	230	170	Tr 140 x 6	51	113	3	80	44,2	RACL1508
5675	523	773	230	170	Tr 140 x 6	51	113	3	80	48,2	RACL15010

▼ Shown from left to right: RACH1504, RACH15010, RACH206, RACH306



The Lightweight Solution for Tensioning and Testing



Saddles

All RACH-cylinders are equipped with bolt-on hollow removable saddles of hardened steel.



Lightweight Hand Pumps

The Enerpac composite lightweight hand pumps P392 or P802 make the optimal lightweight set.

Page: **76**

- Hollow plunger design allows for both pull and push forces
- Composite bearings increase cylinder life and sideload resistance
- Hard-Coat finish on all surfaces resists damage and extends cylinder life
- Floating center tube increases seal and product life
- Handles standard on all models
- Steel base plate and saddle for protection against load-induced damage
- Integral stop ring prevents plunger over-travel and is capable of withstanding the full cylinder capacity
- High strength return spring for rapid cylinder retraction
- CR400 coupler and dustcap included on all models
- All cylinders meet ASME B-30.1 standards.



◀ An RACH306 powered by a P392 hand pump used to extract corroded carriage pins of refuse collection vehicles.

Cylinder Capacity @ 700 bar ton (kN)	Stroke (mm)	Model Number	Cylinder Effective Area (cm ²)
20 (229)	50	RACH202	32,7
	100	RACH204	32,7
	150	RACH206	32,7
	200	RACH208	32,7
	250	RACH2010	32,7
30 (358)	50	RACH302	51,1
	100	RACH304	51,1
	150	RACH306	51,1
	200	RACH308	51,1
	250	RACH3010	51,1
60 (596)	50	RACH602	84,7
	100	RACH604	84,7
	150	RACH606	84,7
	200	RACH608	84,7
	250	RACH6010	84,7
100 (1157)	50	RACH1002	164,6
	100	RACH1004	164,6
	150	RACH1006	164,6
	200	RACH1008	164,6
	250	RACH10010	164,6
150 (1588)	50	RACH1502	225,8
	100	RACH1504	225,8
	150	RACH1506	225,8
	200	RACH1508	225,8
	250	RACH15010	225,8

Single-Acting, Aluminium Hollow Plunger Cylinders

Steel Base Plate Mounting Holes

Cylinder Model / Capacity ton	Bolt Circle U (mm)	Thread V (mm)	Thread Depth ¹⁾ Z (mm)
RACH20	80	M6	12
RACH30	110	M6	12
RACH60	160	M6	12
RACH100	220	M10	12
RACH150	245	M10	12

¹⁾ Including Base Plate Height of 6 mm and four (4) base plate bolts M6.

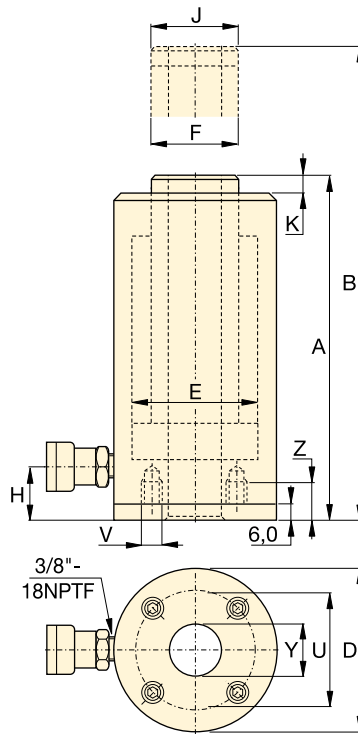

RACH Series

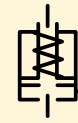

Capacity:

20 - 150 ton

Stroke:

50 - 250 mm

Center Hole Diameter:

27 - 79 mm

Maximum Operating Pressure:

700 bar

Oil Capacity (cm ³)	Collapsed Height A (mm)	Extended Height B (mm)	Outside Diameter D (mm)	Cylinder Bore Diameter E (mm)	Plunger Diameter F (mm)	Bottom to Advance Port H (mm)	Saddle Diameter J (mm)	Saddle Protrusion from Plunger K (mm)	Center Hole Diameter Y (mm)	Weight (kg)	Model Number
164	188	238	100	75	55	29	55	10	27	5,2	RACH202
327	251	351	100	75	55	29	55	10	27	6,1	RACH204
491	315	465	100	75	55	29	55	10	27	7,1	RACH206
654	378	578	100	75	55	29	55	10	27	8,0	RACH208
818	442	692	100	75	55	29	55	10	27	9,0	RACH2010
256	208	258	130	95	70	29	70	10	34	8,0	RACH302
511	267	367	130	95	70	29	70	10	34	9,5	RACH304
766	333	483	130	95	70	29	70	10	34	11,2	RACH306
1022	395	595	130	95	70	29	70	10	34	12,9	RACH308
1277	458	708	130	95	70	29	70	10	34	14,5	RACH3010
423	251	301	180	130	100	61	100	12	54	16,2	RACH602
847	315	415	180	130	100	61	100	12	54	19,5	RACH604
1270	380	530	180	130	100	61	100	12	54	25,6	RACH606
1694	445	645	180	130	100	61	100	12	54	26,0	RACH608
2117	510	760	180	130	100	61	100	12	54	29,6	RACH6010
823	258	308	250	185	145	61	145	14	79	33,8	RACH1002
1646	325	425	250	185	145	61	145	14	79	39,8	RACH1004
2487	391	541	250	185	145	61	145	14	79	46,2	RACH1006
3291	459	659	250	185	145	61	145	14	79	52,2	RACH1008
4114	527	777	250	185	145	61	145	14	79	58,8	RACH10010
1129	280	330	275	205	150	61	145	14	79	48,9	RACH1502
2258	360	460	275	205	150	61	145	14	79	55,7	RACH1504
3387	430	580	275	205	150	61	145	14	79	63,0	RACH1506
4517	500	700	275	205	150	61	145	14	79	70,1	RACH1508
5646	570	820	275	205	150	61	145	14	79	77,2	RACH15010

▼ Shown from left to right: RARH6010 and RARH306



- Lighter and shorter collapsed height than equivalent RACH models
- Double-acting for rapid retraction, regardless of hose lengths or system losses
- Built-in safety valve prevents accidental over-pressurization
- Hollow plunger design allows for both pull and push forces
- Hard coat finish on all surfaces resists damage and extends cylinder life
- Handles and CR400 couplers with dust caps included on all models
- Floating center tube increases seal life
- Steel baseplate and saddle for protection against load-induced damage
- Integral stop ring prevents plunger over-travel and is capable of withstanding the full cylinder capacity
- All cylinders meet ASME B-30.1 standards.

The Lightweight Solution for Double-Acting Applications



Hoses

Enerpac offers a complete line of high-quality hydraulic hoses. To ensure the integrity of your system, specify only Enerpac hydraulic hoses.

Page: 128



Gauges

Minimize the risk of overloading and ensure long, dependable service from your equipment. Refer to the System Components section for a full range of gauges.

Page: 127



4-Way Control Valve

The P84 and P464 hand pumps feature a manual 4-way control valve, designed for use with one double-acting or two single-acting cylinders. For system set-up information:

Page: 78

Cylinder Capacity ton (kN)	Stroke * (mm)	Model Number	Maximum Cylinder Capacity at 700 bar (kN)		Cylinder Effective Area (cm ²)		Oil Capacity (cm ³)	
			Advance	Retract	Advance	Retract	Advance	Retract
30 (359)	50	RARH302	359	187	51,2	26,7	256	134
	150	RARH306	359	187	51,2	26,7	769	401
	250	RARH3010	359	187	51,2	26,7	1281	668
60 (595)	50	RARH602	595	264	84,9	37,7	425	189
	150	RARH606	595	264	84,9	37,7	1274	566
	250	RARH6010	595	264	84,9	37,7	2124	943
100 (1001)	50	RARH1002	1001	568	142,9	81,1	715	405
	150	RARH1006	1001	568	142,9	81,1	2144	1216
	250	RARH10010	1001	568	142,9	81,1	3574	2027
150 (1489)	50	RARH1502	1489	748	212,6	106,8	1063	534
	150	RARH1506	1489	748	212,6	106,8	3190	1602
	250	RARH15010	1489	748	212,6	106,8	5316	2670

* Intermediate strokes and other tonnages available upon request.

Aluminium Double-Acting Hollow Plunger Cylinders



Steel Base Plate

The steel base plate protects the cylinder base from damage, it should not be removed. The base holes in these aluminum cylinders are designed for securing the steel base plate.

They will not withstand the capacity of the cylinder. Do not use the base holes in these aluminum cylinders to attach any device to the cylinder.

Optional Threaded Hollow Saddles

Saddle Type	Cylinder Model Number	Saddle Model Number	Saddle Dimensions (mm)		
			A	B	C
Threaded Hollow	RARH302, 306, 3010	HP3015	63	1 1/4" -7 UN	9
	RARH602, 606, 6010	HP5016	91	1 5/8" -5 1/2 UN	12
	RARH1002, 1006, 10010	HP10016	126	2 1/2" -8 UN	13

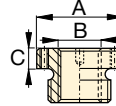

Smooth hollow saddles are standard on all RARH-models.

Steel Base Plate Mounting Holes (mm)

Cylinder Model / Capacity (ton)	Bolt Circle U	Thread V	Thread Depth ¹⁾ Z
RARH30	110	M6	12
RARH60	160	M6	12
RARH100	200	M10	12
RARH150	250	M10	12

¹⁾ Including Base Plate Height of 6 mm and four (4) base plate bolts.

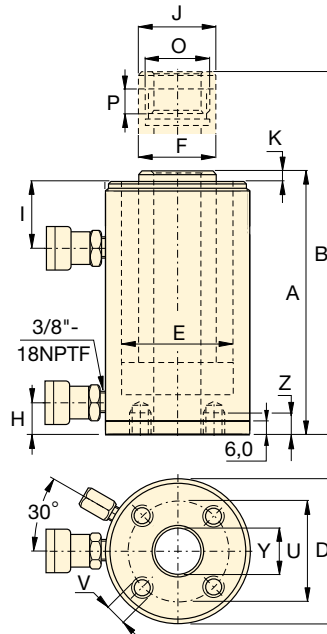

RARH Series



Capacity:

30 - 150 ton

Stroke:

50 - 250 mm

Center Hole Diameter:

34 - 79 mm

Maximum Operating Pressure:

700 bar



RACH-Series, Single-Acting, Spring Return

To be used when a single-acting pump is available and retraction time is not critical.

Page: 16



Pump Selection

A double-acting cylinder must be powered by a pump with a 4-way valve.

Page: 408

Collapsed Height	Extended Height	Outside Diameter	Cylinder Bore Diameter	Plunger Diameter	Cyl. Base to Advance Port	Cyl. Top to Return Port	Saddle Diameter	Saddle Protrusion from Plunger	Plunger Internal Thread	Plunger Thread Length	Center Hole Diameter	Weight (kg)	Model Number
A (mm)	B (mm)	D (mm)	E (mm)	F (mm)	H (mm)	I (mm)	J (mm)	K (mm)	O (inch)	P (mm)	Y (mm)	(kg)	
209	259	135	95	75	22	64	63	10	1 13/16"-16 UN	23	34	8,9	RARH302
309	459	135	95	75	22	64	63	10	1 13/16"-16 UN	23	34	11,9	RARH306
409	659	135	95	75	22	64	63	10	1 13/16"-16 UN	23	34	14,9	RARH3010
246	296	180	130	110	48	83	92	13	2 3/4"-16 UN	20	54	16,8	RARH602
346	496	180	130	110	48	83	92	13	2 3/4"-16 UN	20	54	22,2	RARH606
446	696	180	130	110	48	83	92	13	2 3/4"-16 UN	20	54	27,6	RARH6010
254	304	235	165	130	61	78	126	13,5	4"-16 UN	27	79	28,9	RARH1002
354	504	235	165	130	61	78	126	13,5	4"-16 UN	27	79	38,3	RARH1006
454	704	235	165	130	61	78	126	13,5	4"-16 UN	27	79	47,7	RARH10010
264	314	280	190	150	61	83	127	18,8	4 1/4"-12 UN	40	79	42,4	RARH1502
364	514	280	190	150	61	83	127	18,8	4 1/4"-12 UN	40	79	56,2	RARH1506
464	714	280	190	150	61	83	127	18,8	4 1/4"-12 UN	40	79	70,0	RARH15010

▼ Shown from left to right: RAR5010, RAR308, RAR204



Saddles

All RAR-cylinders are equipped with bolt-on removable hardened steel saddles. For Tilt Saddles see next page.

Page: 21



Hoses

Enerpac offers a complete line of high quality hydraulic hoses. To ensure the integrity of your system, specify only Enerpac hydraulic hoses.

Page: 128

- Double-acting for rapid retraction, regardless of hose lengths or system losses
- Composite bearings increase cylinder life and sideload resistance
- Hard-Coat finish on all surfaces resists damage and extends cylinder life
- Handles and CR400 couplers included on all models
- Steel base plate and saddle for protection against load-induced damage
- Integral stop ring prevents plunger over-travel and is capable of withstanding the full cylinder capacity
- Built-in safety valve prevents accidental over-pressurization.

▼ An RAR506 was easy to position under a bulldozer for repair of frame member.



Cylinder Capacity @ 700 bar ton	Stroke (mm)	Model Number	Max. Cylinder Capacity (kN) Push	Cylinder Effective Area (cm ²)		Oil Capacity (cm ³)	
				Push	Pull	Push	Pull
20	50	RAR202	218	31,2	18,6	156	93
	100	RAR204	218	31,2	18,6	312	186
	150	RAR206	218	31,2	18,6	468	279
	200	RAR208	218	31,2	18,6	624	372
	250	RAR2010	218	31,2	18,6	780	465
30	50	RAR302	309	44,2	24,5	221	123
	100	RAR304	309	44,2	24,5	442	245
	150	RAR306	309	44,2	24,5	663	368
	200	RAR308	309	44,2	24,5	884	490
	250	RAR3010	309	44,2	24,5	1105	613
50	50	RAR502	496	70,9	26,7	354	134
	100	RAR504	496	70,9	26,7	709	267
	150	RAR506	496	70,9	26,7	1063	401
	200	RAR508	496	70,9	26,7	1417	534
	250	RAR5010	496	70,9	26,7	1771	668
100	50	RAR1002	1002	143,1	79,5	715	398
	100	RAR1004	1002	143,1	79,5	1431	795
	150	RAR1006	1002	143,1	79,5	2147	1193
	200	RAR1008	1002	143,1	79,5	2863	1590
	250	RAR10010	1002	143,1	79,5	3578	1988
150	50	RAR1502	1589	227,0	132,0	1135	660
	100	RAR1504	1589	227,0	132,0	2270	1320
	150	RAR1506	1589	227,0	132,0	3405	1980
	200	RAR1508	1589	227,0	132,0	4540	2640
	250	RAR15010	1589	227,0	132,0	5675	3300

Double-Acting Aluminium Cylinders

Optional Bolt-on Tilt Saddle Dimensions (mm)

For Cylinder Model / Capacity ton	Tilt Saddle Model Number	Tilt Saddle Diameter	Addition to Collapsed Height A1
		J1	A1
RAR20	CATS20	42	10
RAR30	CATS30	55	11
RAR50	CATS50	71	14
RAR100	CATS101	71	10
RAR150	CATS150	97	19

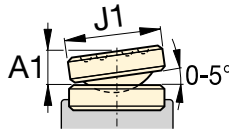

Steel Base Plate Mounting Holes

Cylinder Model / Capacity ton	Bolt Circle U (mm)	Thread V (mm)	Thread Depth ¹⁾ Z (mm)
RAR20	93	M6	12
RAR30	105	M6	12
RAR50	110	M6	12
RAR100	165	M6	12
RAR150	200	M6	12

¹⁾ Including Base Plate Height of 6 mm and four (4) base plate bolts M6.

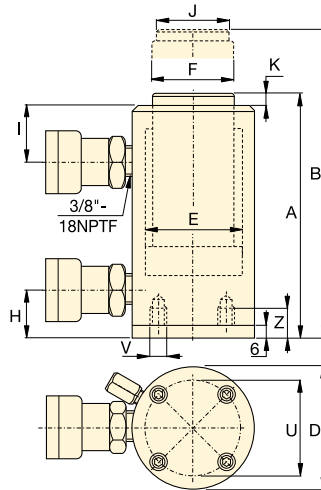

RAR Series



Capacity:

20 - 150 ton

Stroke:

50 - 250 mm

Maximum Operating Pressure:

700 bar

Collapsed Height A (mm)	Extended Height B (mm)	Outside Diameter D (mm)	Cylinder Bore Diameter E (mm)	Plunger Diameter F (mm)	Bottom to Advance Port H (mm)	Top to Retract Port I (mm)	Saddle Diameter J (mm)	Saddle Protrusion from Plunger K (mm)	Weight (kg)	Model Number
189	239	113	63	40	30	50	30	3	7,4	RAR202
239	339	113	63	40	30	50	30	3	8,0	RAR204
289	439	113	63	40	30	50	30	3	8,6	RAR206
339	539	113	63	40	30	50	30	3	9,2	RAR208
389	639	113	63	40	30	50	30	3	9,8	RAR2010
201	251	125	75	50	30	55	40	3	8,6	RAR302
251	351	125	75	50	30	55	40	3	9,5	RAR304
301	451	125	75	50	30	55	40	3	10,4	RAR306
351	551	125	75	50	30	55	40	3	11,3	RAR308
401	651	125	75	50	30	55	40	3	12,2	RAR3010
201	251	145	95	75	30	56	50	3	11,1	RAR502
251	351	145	95	75	30	56	50	3	12,7	RAR504
301	451	145	95	75	30	56	50	3	14,3	RAR506
351	551	145	95	75	30	56	50	3	15,9	RAR508
401	651	145	95	75	30	56	50	3	17,5	RAR5010
251	301	185	135	90	43	80	75	3	16,4	RAR1002
301	401	185	135	90	43	80	75	3	19,3	RAR1004
351	501	185	135	90	43	80	75	3	22,2	RAR1006
401	601	185	135	90	43	80	75	3	25,1	RAR1008
451	701	185	135	90	43	80	75	3	28,0	RAR10010
248	298	230	170	110	38	75	94	3	24,2	RAR1502
298	398	230	170	110	38	75	94	3	28,9	RAR1504
348	498	230	170	110	38	75	94	3	33,2	RAR1506
398	598	230	170	110	38	75	94	3	37,9	RAR1508
448	698	230	170	110	38	75	94	3	42,6	RAR15010

▼ CULP50 Ultra-Flat Cylinder, with Stop Ring



- Up to 4% side load of maximum capacity
- Stop ring for maximum stroke limitation
- Extremely low collapsed height
- Nitrocarburized surface treatment for harsh conditions.

▼ The Ultra-Flat cylinders are designed for applications where high lifting forces are required in confined spaces starting at 2,8 cm.

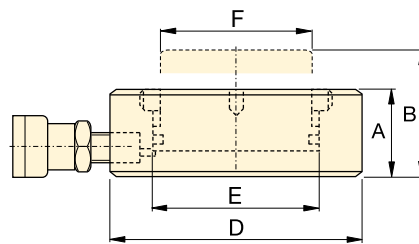

CULP Series

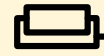

Capacity:

10 - 100 ton

Stroke:

6 mm

Maximum Operating Pressure:

700 bar



IMPORTANT!

All Ultra-Flat Cylinders require a solid lifting surface for correct support. The use of these flat cylinders on surfaces such as sand, mud or dirt, may result in cylinder damage.



INCORRECT!

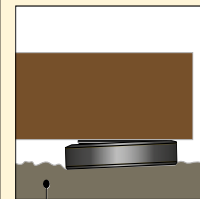

Rough soil



CORRECT!

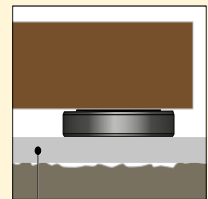

Flat lifting surface

For more safety instructions see our 'Yellow Pages'.

Page: **406**



Hoses

Enerpac offers a complete line of high quality hydraulic hoses. To ensure the integrity of your system, specify only Enerpac

hydraulic hoses.

Page: **128**

Cylinder Capacity @ 700 bar ton (kN)	Stroke (mm)	Model Number	Cylinder Effective Area (cm ²)	Oil Capacity (cm ³)	Collapsed Height		Outside Diameter D (mm)	Cylinder Bore Diameter E (mm)	Plunger Diameter F (mm)	 (kg)
					A (mm)	B (mm)				
10 (97)	6	CULP10 ¹⁾	13,9	8,3	27,5	33,5	72	42	38	1,0
20 (198)	6	CULP20 ¹⁾	28,3	17,0	32,0	38,0	90	60	55	1,7
30 (310)	6	CULP30 ¹⁾	44,2	26,5	35,0	41,0	105	75	67	2,5
50 (550)	6	CULP50 ¹⁾	78,5	47,1	44,5	50,5	140	100	90	5,4
100 (1078)	6	CULP100 ²⁾	153,9	92,5	65,0	71,0	195	140	125	11,5

¹⁾ Coupler AR630 including dustcap: use HB7206 hose including AH630 coupler to connect to your pump.

²⁾ Coupler CR400 including dustcap: use HC-Series hose including CH604 coupler to connect to your pump.

High Tonnage, Ultra-Flat Cylinders

▼ CUSP-Series, Ultra-Flat High Tonnage Cylinders, integrated tilting function.



- Up to 4% side load of maximum capacity
- Extremely low collapsed height
- Integrated tilting function up to 4 degrees to evenly distribute the load
- Nitrocarburized surface treatment for harsh conditions
- “Red Line” for visual maximum stroke indication.

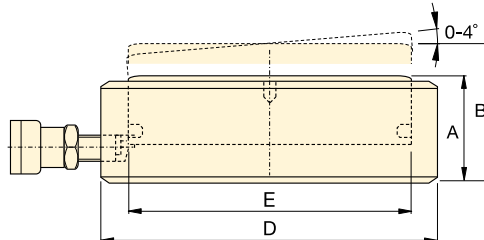

CUSP Series

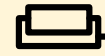

Capacity:

10 - 1000 ton

Stroke Straight / Tilted Stroke:

7 - 17 mm / 6 - 10 mm

Integrated:

Tilting Function

Maximum Operating Pressure:

700 bar



IMPORTANT!

CUSP-Cylinders DO NOT have a Stop Ring for stroke limitation!



IMPORTANT!

All Ultra-Flat Cylinders require a solid lifting surface for correct support. The use of these flat cylinders on surfaces such as sand, mud or dirt, may result in cylinder damage.

See instructions on page 22 or more safety instructions in our Yellow Pages.

Page: 406

Cylinder Capacity @ 700 bar	Tilted Stroke	Straight Stroke	Model Number	Tilting +/-	Cylinder Effective Area	Oil Capacity	Collapsed Height	Extended Height	Cylinder Outside Diameter	Cylinder Bore Diameter	
ton (kN)	(mm)	(mm)		(degree)	(cm ²)	(cm ³)	A (mm)	B (mm)	D (mm)	E (mm)	(kg)
10 (97)	6	6,7	CUSP10 ¹⁾	2	13,9	9,3	35,5	41,5	72	42	1,2
20 (198)	6	7,0	CUSP20 ¹⁾	2	28,3	19,8	40,5	46,5	90	60	1,9
30 (310)	6	7,3	CUSP30 ¹⁾	2	44,2	32,1	42,5	48,5	105	75	2,7
50 (550)	10	13,3	CUSP50 ¹⁾	4	78,5	104	57,0	67,0	130	100	5,6
75 (792)	10	14,0	CUSP75 ¹⁾	4	113,1	158	60,5	70,5	150	120	8,0
100 (1078)	10	14,7	CUSP100 ²⁾	4	153,9	226	63,5	73,5	170	140	10,8
150 (1589)	10	14,3	CUSP150 ²⁾	3	227,0	324	65,0	75,0	200	170	15,3
200 (2090)	10	14,9	CUSP200 ²⁾	3	298,6	446	69,0	79,0	229	195	21,5
250 (2542)	10	15,5	CUSP250 ²⁾	3	363,1	569	72,5	82,5	252	215	27,3
300 (3167)	10	14,1	CUSP300 ²⁾	2	452,4	637	72,5	82,5	282	240	34,4
400 (4008)	10	14,6	CUSP400 ²⁾	2	572,6	837	77,5	87,5	316	270	46,2
500 (5115)	10	15,2	CUSP500 ²⁾	2	730,6	1111	82,5	92,5	356	305	62,7
600 (5987)	10	15,6	CUSP600 ²⁾	2	855,3	1334	87,5	97,5	386	330	78,4
750 (7527)	10	16,3	CUSP750 ²⁾	2	1075,2	1757	93,5	103,5	432	370	105,2
1000 (10.165)	10	17,4	CUSP1000 ²⁾	2	1452,2	2531	103,0	113,0	502	430	157,0

¹⁾ Coupler AR630 including dustcap: Use HB7206 hose including AH630 coupler to connect to your pump.

²⁾ Coupler CR400 including dustcap: Use HC-Series hose including CH604 coupler to connect to your pump.

▼ LPL-Series, Low-Height Lock Nut Cylinders



- Lock nut provides mechanical load holding for a safe work environment
- Integrated tilt saddle allows for up to 5 degrees of misalignment
- Extreme low height for use in confined areas
- Side-load resistance 5-10% of maximum capacity
- Overflow port as stroke limiter to prevent plunger blow-out
- Single-acting, gravity-return.

▼ Only the extreme low-height LPL-cylinder fits in this confined area to lift the construction. The lock nut provides positive and safe mechanical load holding over a long period of time.



Integrated Tilt Saddles

All LPL-Series cylinders include integral tilt saddles with maximum tilt angles up to 5°.



The Summit Edition

Innovation is at the heart of the new Summit Edition of cylinders, delivering the high quality construction that you expect from Enerpac. The durability ensures your job gets done safely and reliably.

- Replaceable plunger support bearing adds support for eccentric loads *
- Nitrocarburization surface treatment for improved load and wear resistance and corrosion protection
- Low wear, high pressure seals provide longer service life.

* Eccentric load (or "side-load") is inevitable in heavy lifting. Our unique Summit Edition features provide the ultimate protection against side load. Increased bearing surface maintains stability and nitrocarburization treatment prevents scoring on the inside of the cylinder. Side-load poses a real problem.... our new cylinder features are the solution!

Cylinder Capacity	Stroke	Model Number	Maximum Cylinder Capacity at 700 bar ton (kN)	Side-load Resistance of Maximum Capacity	Cylinder Effective Area
ton	(mm)				(cm ²)
60	50	LPL602	62 (606)	10%	86,6
100	50	LPL1002	102 (1002)	10%	143,1
150	45	LPL1602	162 (1589)	8%	227,0
200	45	LPL2002	202 (1985)	8%	283,5
250	45	LPL2502	259 (2541)	5%	363,1
400	45	LPL4002	409 (4008)	5%	572,6
500	45	LPL5002	522 (5114)	5%	730,6

Single-Acting, Low-Height Lock Nut Cylinders



IMPORTANT!

All LPL-Series cylinders require a solid lifting surface for correct support. The use of these cylinders on surfaces such as sand, mud or dirt, may result in cylinder damage.

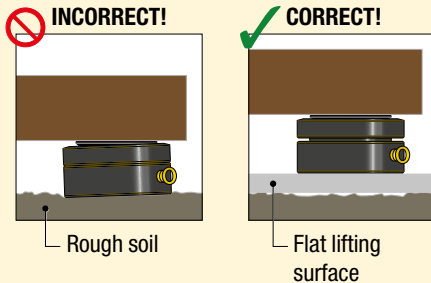

For more safety instructions see our 'Learning Center' on www.enerpac.com

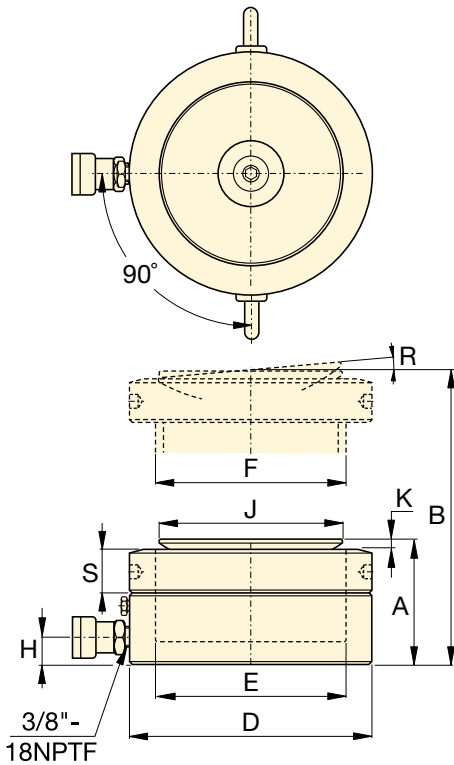

LPL Series



Capacity:

60 - 500 ton

Stroke:

45 - 50 mm

Maximum Operating Pressure:

700 bar



Longer Stroke Lock Nut Cylinders

For longer stroke applications **HCL and HCRL-Series** lock nut cylinders are the perfect choice.

Page: 46



SFP-Series, Split-Flow Pumps

SFP-Series Pumps with multiple outlets with equal oil flow. For lifting and lowering applications on multiple points

these pumps are a far better alternative than using separately operated pumps.

Page: 406



Synchronous Lifting Systems

EVO-Series pumps the multi-functional lifting system and multiple lift point capabilities.

Page: 350

Oil Capacity	Collapsed Height	Extended Height	Outside Diameter	Cylinder Bore Diameter	Plunger Diameter	Base to Advance Port	Saddle Diameter	Saddle Protrusion from Plgr.	Saddle Max. Tilt Angle	Lock Nut Height	 (kg)	Model Number
(cm ³)	A (mm)	B (mm)	D (mm)	E (mm)	F (mm)	H (mm)	J (mm)	K (mm)	R	S (mm)		
433,0	126	176	140	105	Tr 105 x 4	19	96	7	5°	28	15	LPL602
715,7	137	187	173	135	Tr 135 x 6	21	126	8	5°	31	25	LPL1002
1021,4	148	193	220	170	Tr 170 x 6	27	160	9	5°	40	43	LPL1602
1275,9	155	200	245	190	Tr 190 x 6	30	180	10	5°	43	55	LPL2002
1633,7	159	204	275	215	Tr 215 x 6	32	200	12	5°	43	70	LPL2502
2576,5	178	223	350	270	Tr 270 x 6	40	250	12	4°	55	129	LPL4002
3287,8	192	237	400	305	Tr 305 x 6	49	290	10	3°	61,5	183	LPL5002

▼ Shown from left to right: RSM1000, RSM300, RSM50, RCS1002, RCS302



Maximum Power-to-Height Ratio



Saddles

All RCS-Series cylinders have plunger mounting holes for installation of tilt saddles. See table for selection and dimensional information.

Page: 27



Low Clearance Lifting

The LW-Series Lifting Wedges and SOH-Series Machine Lifts are the perfect choice for lifting the first few millimeters.

Page: 188

RSM-series, Low-Height Cylinders

- Compact, flat design for use where most other cylinders will not fit
- Single-acting, spring return
- RSM750, 1000 and 1500 have handles for easy carrying
- Mounting holes permit easy fixturing
- Baked enamel finish for increased corrosion resistance
- CR400 coupler and dust cap included on all models¹⁾
- Hard chrome plated high quality steel plungers
- Grooved plunger ends require no saddle.

RCS-series, Low-Height Cylinders

- Lightweight, low profile design for use in confined spaces
- Single-acting, spring return
- Baked enamel finish for increased corrosion resistance
- Plunger wiper reduces contamination, extending cylinder life
- CR400 coupler and dust cap included on all models
- Grooved plunger end with threaded holes for mounting tilt saddles
- Integral handle on RCS1002 for easy carrying
- Plated steel plungers.

▼ Only a couple of centimeters will do for an RSM-cylinder to lift a large construction.

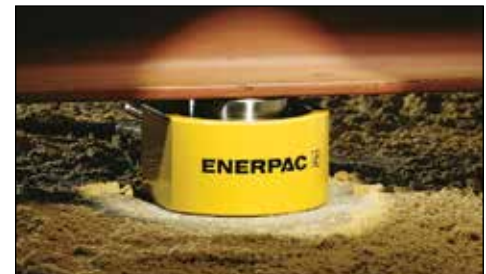

Cyl. Capacity	Stroke	Model Number	Cylinder Effective Area	Oil Capacity
ton (kN)	(mm)		(cm ²)	(cm ³)
5 (45)	6	RSM50 ¹⁾	6,5	4
10 (101)	11	RSM100 *	14,5	18
20 (201)	11	RSM200 *	28,7	32
30 (295)	13	RSM300 *	42,1	55
45 (435)	16	RSM500 *	62,1	99
75 (718)	16	RSM750	102,6	164
90 (887)	16	RSM1000	126,7	203
150 (1386)	16	RSM1500	198,1	317
10 (101)	38	RCS101 *	14,5	55
20 (201)	45	RCS201 *	28,7	129
30 (295)	62	RCS302 *	42,1	261
45 (435)	60	RCS502 *	62,1	373
90 (887)	57	RCS1002 *	126,7	722

¹⁾ RSM50 is fitted with an AR400 coupler.

* Available as set, see note on next page.

Single-Acting, Low-Height Cylinders

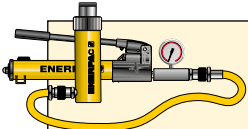

Cylinder-Pump Sets

All cylinders marked with an * are available as sets (cylinder, gauge, couplers, hose and pump) for your ordering convenience.

Page: **62**

Optional Bolt On Tilt Saddle Dimensions (mm)

For Cylinder Model:	Model Number	J1	A1 *
RCS101	CATS13	35	20
RCS201, 302, 502	CATS53	50	26
RCS1002	CATS103	71	35

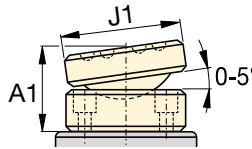

* A1 = Addition to Collapsed Height.

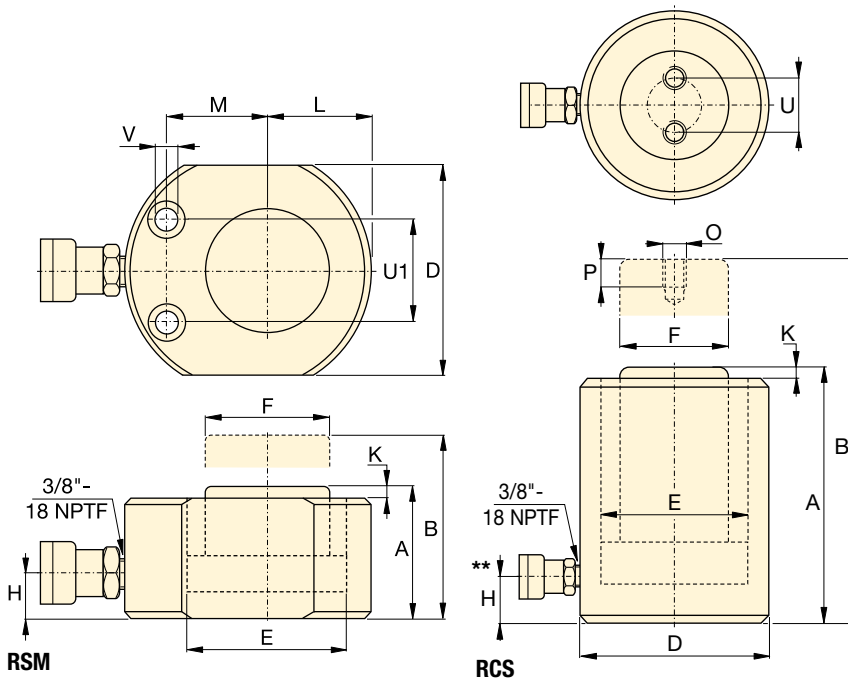

RSM, RCS Series



Capacity:

5 - 150 ton

Stroke:

6 - 62 mm

Maximum Operating Pressure:

700 bar



Power Box

Tool box with hand pump, gauge adaptor assembly, hose and RSM or RCS-cylinders.

Page: **65**

RSM Cylinder Mounting Hole Dimensions (mm)

Model Number	Bolt Circle U1	Hole Dia. V	Counter Bore Dia.	Counter Bore Depth
RSM50	28,5	5,5	9,1	4,3
RSM100	36,6	7,1	10,7	7,9
RSM200	49,3	10,0	15,1	9,9
RSM300	52,3	10,0	15,9	11,2
RSM500	66,5	11,0	19,0	12,7
RSM750	76,2	13,5	20,6	14,2
RSM1000	76,2	13,5	20,6	14,2
RSM1500	117,3	13,5	20,6	14,2

Collapsed Height	Extended Height	Outside Diameter	Cylinder Bore Dia.	Plunger Dia.	Base to Advance Port	Plunger Protrusion from Base	Plunger to Base	Plunger to Mtg. Hole	Thread	Thread Depth	Bolt Circle	Weight	Model Number
A (mm)	B (mm)	D (mm)	E (mm)	F (mm)	H (mm)	K (mm)	L (mm)	M (mm)	O (mm)	P (mm)	U (mm)	(kg)	
32	38	58 x 41	28,7	25,4	16	1	20	22	-	-	-	1,0	RSM50 ¹⁾
43	54	82 x 55	42,9	38,1	19	1	27	34	-	-	-	1,4	RSM100 *
51	62	101 x 76	60,5	50,8	19	1	39	39	-	-	-	3,1	RSM200 *
58	71	117 x 95	73,2	63,4	19	2	47	44	-	-	-	4,5	RSM300 *
66	82	140 x 114	88,9	69,8	19	2	57	53	-	-	-	6,8	RSM500 *
79	95	165 x 139	114,3	82,6	19	2	69	66	-	-	-	11,3	RSM750
85	101	178 x 153	127,0	92,2	19	2	76	74	-	-	-	14,5	RSM1000
100	116	215 x 190	158,8	114,3	23	2	95	82	-	-	-	26,3	RSM1500
88	126	69	42,9	38,1	17	5	-	-	M4	8	26	2,7	RCS101 *
98	143	92	60,5	50,8	17	3	-	-	M5	8	40	5,0	RCS201 *
117	179	101	73,2	66,5	19	3	-	-	M5	8	40	6,8	RCS302 *
122	182	124	88,9	69,8	23	2	-	-	M5	8	40	10,0	RCS502 *
141	198	165	127,0	92,2	31	1	-	-	M8	10	55	20,7	RCS1002 *

** 5° angle position of coupler on RCS101, 201, 302.

▼ RLT-Series, Low-Height Telescopic Cylinder



- **Single-acting, load-return**
- **Nitrocarburized surface treatment inside and out provides corrosion protection**
- **For use in confined spaces: machinery positioning, tool fastening**
- **Mounting bolt holes for easy fixing**
- **Up to 3% side-load of maximum capacity**
- **Design safety factor complies with ASME B30.1 & EN1494**
- **CR400 coupler for compatibility with standard product**
- **High-Alloy steel for maximum strength.**

For longer cylinder strokes in confined spaces



RLT-Series, Low-Height Telescopic Cylinders

Enerpac compact, low-height telescopic cylinders are available with two or three pistons, and can lift loads up to 40 mm in a single movement.

Nitrocarburization surface treatment for improved wear resistance and corrosion protection for increased safety and longer service life in harsh conditions. The longer stroke length of telescopic cylinders will save you time and simplify projects by moving a load a greater distance and eliminating the use of temporary cribbing.



Multi-Stage Cylinders

1st Stage: maximum load capacity at lower stroke.

2nd Stage: extended stroke with lower capacity than the 1st stage.

Final Stage: maximum stroke extension with lowest capacity.



Cylinder Capacity at Maximum Stroke ton (kN)	Maximum Stroke (mm)	Model Number	Collapsed Height	Extended Height	Oil Capacity (cm ³)
			A (mm)	B (mm)	
4,4 (43)	17	RLT40	45,0	62,0	21
4,4 (43)	23	RLT41	54,0	77,0	51
11,4 (111)	18	RLT110	54,5	72,5	48
11,4 (111)	40	RLT111	89,0	129,0	241
23,7 (232)	27	RLT230	75,0	102,0	150
23,7 (232)	32	RLT231	96,0	128,0	303
31,5 (309)	29	RLT311	89,0	118,0	224
50,6 (496)	26	RLT501	96,0	122,0	283
74,1 (727)	26	RLT741	114,0	140,0	426

Low-Height Telescopic Cylinders, Single-Acting



Assisted-return Pumps with Venturi Valve Technology

To improve productivity and plunger retraction,

Enerpac offers valve configurations designed to accelerate your cylinder retraction speeds, ZU4 and ZE-Series pumps feature **Venturi Valve Technology** to facilitate the faster return of single-acting load and spring-return cylinders. See enerpac.com for details.

Page: 123



4-way Manifold assembly

Offering ease of portability and convenience with an ergonomic robust design, ready for use. Enerpac's

CR400 female couplers on all ports allow the manifold to be quickly connected to up to 4 cylinders. Glycerine filled, 700 bar gauges allow operators to work safely. All protected by the robust protection frame.

Manifold Type (Used for cylinders)	Model Number
4x Single-acting	AMGC41
4x Double-acting	AMGC42

Page: 132

RLT Series



Capacity:

4,4 - 74,1 ton

Stroke:

17 - 40 mm

Maximum Operating Pressure:

700 bar



WARNING: If several telescopic cylinders need to be controlled simultaneously Enerpac recommend the use of **EVOP** or **EVO-Series**

Synchronous Lifting Pumps. Enerpac advise not to use SFP-Series Split-Flow pumps to operate several telescopic cylinders at a time due to the volume difference on the different stages.

Page: 350

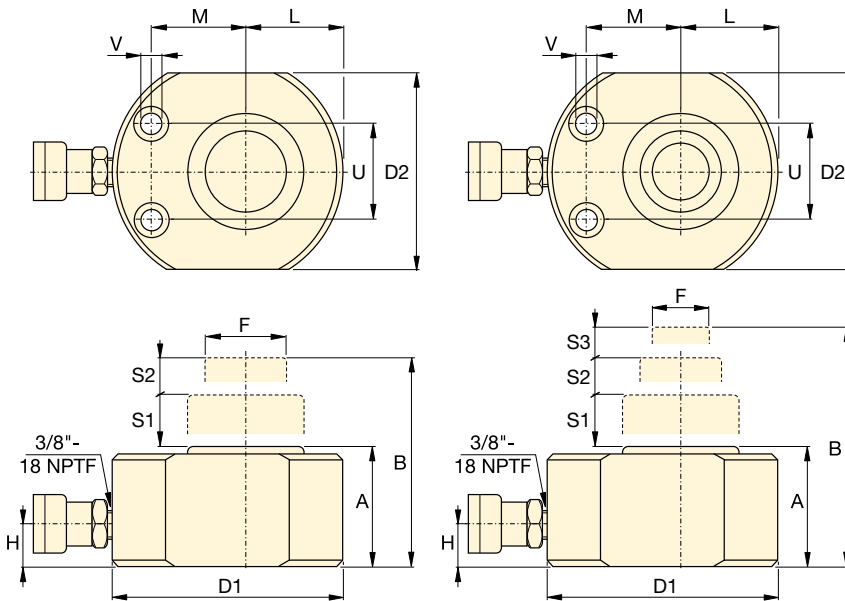

RLT-Cylinders

Mounting Hole Dimensions (mm)

Model Number	Bolt Distance	Hole Diameter	Counter Bore Diameter	Counter Bore Depth
	U	V		
RLT40	37	6,5	11	7
RLT41	50	9,0	14	9
RLT110	50	9,0	14	9
RLT111	76	13,0	20	13
RLT230	67	13,0	20	13
RLT231	76	6,5	11	7
RLT311	76	13,0	20	13
RLT501	76	6,5	11	7
RLT741	117	9,0	14	9

1st Stage		2nd Stage		3rd Stage		Outside Diameter D1 x D2 (mm)	Plunger Diameter F (mm)	Bottom to Advance Port H (mm)	Plunger to Base L (mm)	Plunger to Mounting Hole M (mm)	 (kg)	Model Number
Capacity ton (kN)	Stroke S1 (mm)	Capacity ton (kN)	Stroke S2 (mm)	Capacity ton (kN)	Stroke S3 (mm)							
11,4 (111)	11	4,4 (43)	6	-	-	83 x 56	25	20	29,0	33	1,8	RLT40
23,7 (232)	11	11,4 (111)	7	4,4 (43)	5	102 x 80	25	20	41,0	39	3,1	RLT41
23,7 (232)	11	11,4 (111)	7	-	-	102 x 80	38	20	41,0	39	3,0	RLT110
74,1 (727)	16	31,5 (309)	13	11,4 (111)	11	165 x 140	38	25	70,5	66	13,1	RLT111
50,6 (496)	16	23,7 (232)	11	-	-	140 x 114	57	20	58,0	56	7,6	RLT230
94,7 (929)	16	50,6 (496)	10	23,7 (232)	6	178 x 162	57	29	89,0	70	17,3	RLT231
74,1 (727)	16	31,5 (309)	13	-	-	165 x 140	60	25	70,5	66	13,0	RLT311
94,7 (929)	16	50,6 (496)	10	-	-	178 x 162	78	29	89,0	70	17,3	RLT501
143,5 (1407)	16	74,1 (727)	10	-	-	216 x 196	95	35	108,0	78	30,4	RLT741

▼ RT3311 Telescopic Cylinder (shown with plunger extended and retracted)



- Nitrocarburized surface treatment inside and out provides corrosion protection
- 3% side-load of full capacity
- Double or triple wear bearings support lifting stages
- Tilting saddles with 5 degrees of maximum tilt standard on all models
- Design Safety factor complies with ASME B30.1 & EN1494
- Certified lifting eyes for safe handling and positioning
- CR400 coupler for compatibility with standard product
- Steel cylinder base for maximum strength.



◀ *The longer stroke length of telescopic cylinders will save you time and simplify projects by moving a load a greater distance and eliminating the use of temporary cribbing.*

Moving a load a greater distance



RT-Series, Multi-Stage Cylinders

Enerpac compact, multi-stage telescopic cylinders are available with two or three pistons, and can lift loads up to 600 mm in a single movement.

Nitrocarburized surface treatment inside and out provides unparalleled sideload resistance and corrosion protection for safe use in the harshest conditions. The longer stroke length of telescopic cylinders will save you time and simplify projects by moving a load a greater distance and eliminating the use of temporary cribbing.

Multi-Stage Cylinders

1st Stage: maximum load capacity at lowest maximum stroke

2nd Stage: extended stroke but at lower maximum capacity than the 1st stage

Final Stage: maximum stroke extension but lowest maximum capacity.

WARNING: If several telescopic cylinders need to be controlled simultaneously Enerpac recommend the use of EVO or EVOB-Series Synchronous Lifting Pumps. Enerpac advise not to use SFP-Series Split-Flow pumps to operate several telescopic cylinders at a time due to the volume difference on the different stages.



Tilt Saddles

All RT-Series cylinders include integral tilt saddles with maximum tilt angles up to 5 degree.

Cylinder Capacity at Maximum Stroke ton (kN)	Maximum Stroke (mm)	Model Number	Collapsed Height	
			A (mm)	B (mm)
14,0 (137)	270	RT1510	283	553
		RT1817	345	780
20,2 (198)	300	RT2111	317	617
	500	RT2119	395	895
31,5 (309)	300	RT3311	352	652
	600	RT3323	476	1076

Multi-Stage Telescopic Cylinders, Single-Acting, Load Return

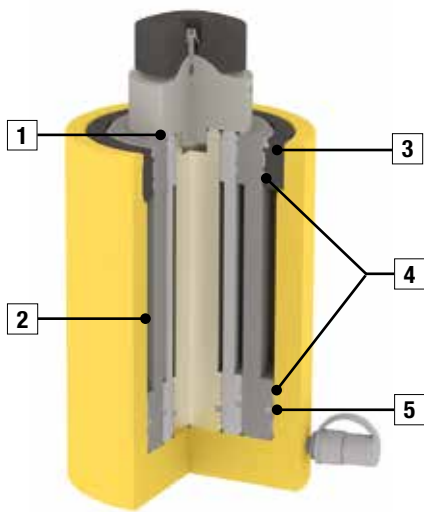

- 1 **Wiper Ring** on each stage to minimize contamination.
- 2 **Nitrocarburized Coating** for maximum corrosion protection and surface hardness. Exterior in nitrided and Enerpac yellow epoxy.
- 3 **Stop Ring** full load capable to prevent plunger overstroke.
- 4 **Wear Bearings**. Double or triple wear bearings for maximum sideload capability and wear resistance.
- 5 **Seals** for maximum compliance and high wear resistance.

RT Series



Capacity:
14 - 31,5 ton

Stroke:
270 - 600 mm

Maximum Operating Pressure:
700 bar

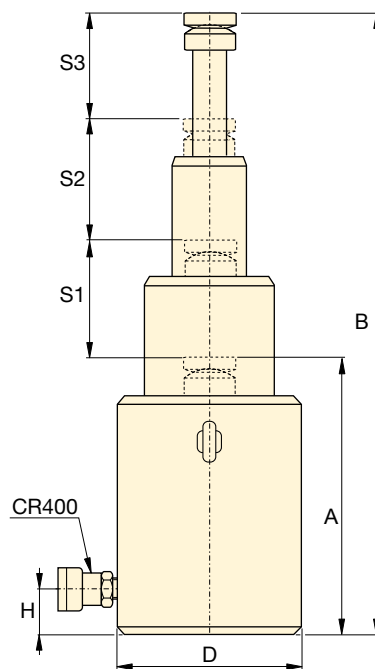
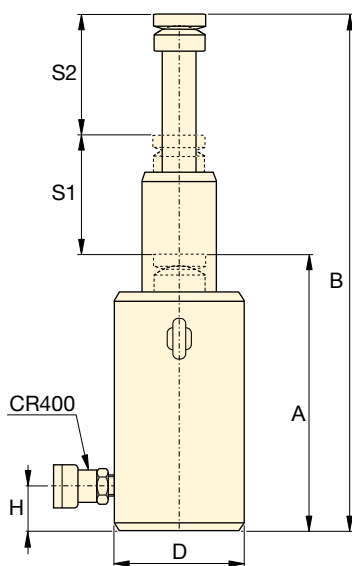
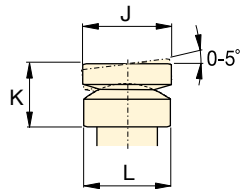

Assisted-return Pumps with Venturi Valve Technology

To improve productivity and plunger retraction, Enerpac offers valve configurations designed to

accelerate your cylinder retraction speeds, ZU4 and ZE-Series pumps feature **Venturi Valve Technology** to facilitate the faster return of single-acting load and spring-return cylinders. See enerpac.com for details.

Page: 123



Hoses

Enerpac offers a complete line of high quality hydraulic hoses. To ensure the integrity of your system, specify only Enerpac

hydraulic hoses.

Page: 128

Oil Capacity (cm ³)	1st Stage		2nd Stage		3rd Stage		Outside Diameter D (mm)	Bottom to Advance Port H (mm)	Saddle Diameter J (mm)	Saddle Protrusion from Plgr. K (mm)	Saddle Support Diameter L (mm)	Model Number
	Capacity ton (kN)	Stroke S1 (mm)	Capacity ton (kN)	Stroke S2 (mm)	Capacity ton (kN)	Stroke S3 (mm)						
944	36 (352)	135	14 (137)	135	-	-	110	20	60	49	60	15,1 RT1510
3092	95 (929)	145	41 (397)	145	17,0 (166)	145	170	27	80	73	85	40,3 RT1817
1487	51 (496)	150	20 (198)	150	-	-	125	23	60	53	66	21,8 RT2111
4661	126 (1237)	170	51 (496)	170	20,2 (198)	160	200	34	90	83	100	67,3 RT2119
2359	81 (792)	150	32 (309)	150	-	-	160	25	80	66	89	39,9 RT3311
8816	202 (1985)	200	81 (792)	200	31,5 (309)	200	250	44	110	111	123	124,0 RT3323

▼ Shown from left to right: BRC25, BRC46, BRP306, BRP606, BRP106C



- High strength alloy steel construction
- Hard chrome-plated plunger for long life
- Replaceable links on BRP-models
- Baked enamel finish for increased corrosion resistance
- CR400 coupler and dust cap included on all models
- Plunger wiper reduces contamination, extending cylinder life
- Single-acting, spring return.

The Ultimate in Pulling Power



Gauges

Minimize the risk of overloading and ensure long, dependable service from your equipment. Refer to the System Components Section for a full range of gauges.

Page: 127



Attachments and Accessories

BRC25 and BRC46 units have base, collar and plunger threads to affix a range of optional attachments and accessories, such as chains, saddles and extension tubes.

Page: 181

▼ Lifting mining conveyor belt using pull cylinders for bearing maintenance.



▼ To lift a load bearing mast into place, BRP-Series cylinders were used to tension the supporting cables.



Single-Acting, Pull Cylinders

BRC Cylinder Mounting Dimensions (mm)				
Model Number	Base Mounting Hole V	Collar Thread W	Collar Thd. Lgth. X	Mtg. Thd. Lgth. Z
BRC-25	3/4" - 14 NPT	1 1/2" - 16 UN	24	17
BRC-46	1 1/4" - 11 1/2 NPT	2 1/4" - 14 UN	26	24
BRC-106	M30 x 2	M85 x 2	25	24

**BRC,
BRP
Series**



Capacity:

2,5 - 50 ton

Stroke:

127 - 154 mm

Maximum Operating Pressure:

700 bar

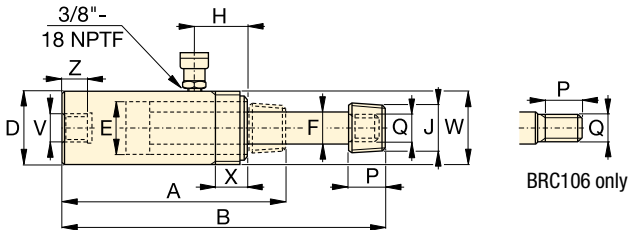

BRC25, 46, 106

Cylinder Capacity	Stroke	Model Number	Cylinder Effective Area	Oil Capacity	Coll. Height	Ext. Height	Outside Dia.	Cylinder Bore Dia.	Plunger Dia.	Top to Inlet Port H	Saddle Diameter	Plunger Thread Length P	Plunger Outside Thread Q	
ton (kN)	(mm)		(cm ²)	(cm ³)	A (mm)	B (mm)	D (mm)	E (mm)	F (mm)	H (mm)	J (NPT)	P (mm)	Q	(kg)
2,5 (24)	127	BRC25	3,5	45	264	391	48	28,4	19,0	45	3/4" - 14	28	1 1/16" - 24	1,8
5 (51)	140	BRC46	7,3	101	301	441	57	42,9	30,2	42	1 1/4" - 11 1/2	32	1 3/16" - 16	4,5
10 (105)	151	BRC106	15,0	228	289	440	85	54,1	31,8	39	-	25	M30x2	9,5

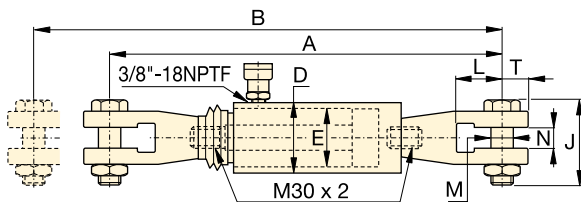

BRP106C

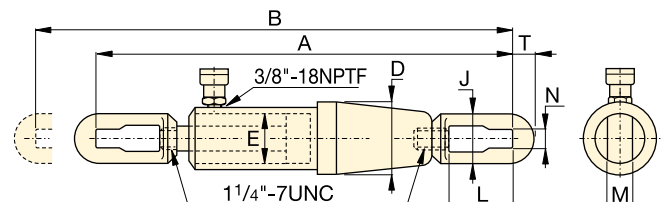

BRP306

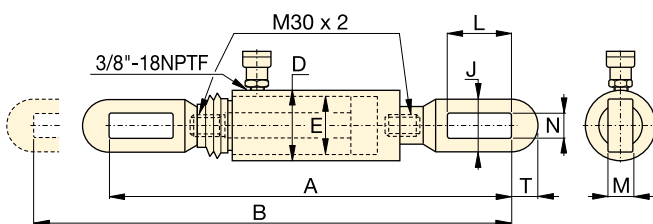

BRP106L

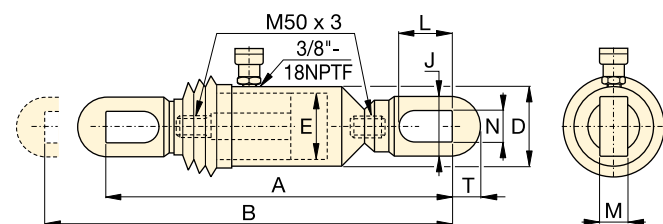

BRP606

Cylinder Capacity	Stroke	Model Number	Cylinder Effective Area	Oil Capacity	Coll. Height	Ext. Height	Outside Dia.	Cyl. Bore Dia.	Link Height	Link Opening L	Link Thickness M	Link Width N	Slot to Link End T	
ton (kN)	(mm)		(cm ²)	(cm ³)	A (mm)	B (mm)	D (mm)	E (mm)	J (mm)	L (mm)	M (mm)	N (mm)	T (mm)	(kg)
10 (110)	150	BRP106C	15,8	238	601	751	85	54,1	105	87	30	35	32	15,3
	150	BRP106L	15,8	238	573	723	85	54,1	64	119	22	30	32	13,3
30 (325)	154	BRP306	46,4	715	1110	1264	137	88,9	114	155	35	40	55	63,1
50 (506)	153	BRP606	72,1	1096	718	871	140	110,1	130	151	40	48	65	58,3

▼ Shown from left to right: RCH306, RCH120, RCH1003



- Hollow plunger design allows for both, pull and push forces
- Single-acting, spring return
- Nickel-plated, floating center tube on models over 20 ton increases product life
- Baked enamel finish for increased corrosion resistance
- Collar threads for easy fixturing
- RCH120 includes AR630 coupler and has 1/4" NPTF port
- RCH121 and RCH1211 have FZ1630 reducer and AR630 coupler, all other models feature CR400 coupler.

▼ Hollow plunger cylinder RCH1003 used in an application for intermediate boom suspension on a dragline.



Versatility in Testing, Maintenance and Tensioning Applications

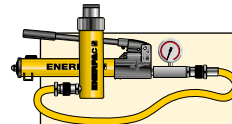

Cylinder-Pump Sets

All cylinders marked with an * are available as **sets** (cylinder, gauge, couplers, hose and pump) for your ordering convenience.

Page: 62



Ultra-Lightweight Aluminium Cylinders

If you need a higher cylinder capacity-to-weight-ratio the lightweight **RACH-Series** are the perfect choice.

Page: 16



Saddles

Most RCH-Series cylinders are equipped with smooth saddles. See table at next page for optional threaded saddles and all dimensional information.

Page: 35

Cylinder Capacity	Stroke	Model Number	Cylinder Effective Area	Oil Capacity
ton (kN)	(mm)		(cm ²)	(cm ³)
12 (125)	8	RCH120	17,9	14
	42	RCH121 *	17,9	75
	42	RCH1211	17,9	75
	76	RCH123	17,9	136
20 (215)	49	RCH202 *	30,7	150
	155	RCH206	30,7	476
30 (326)	64	RCH302 *	46,6	298
	155	RCH306	46,6	722
60 (576)	76	RCH603 *	82,3	626
	153	RCH606	82,3	1259
95 (931)	76	RCH1003 *	133,0	1011

* Available as set, see note on this page.

Single-Acting, Hollow Plunger Cylinders



Hoses

Enerpac offers a complete line of high quality hydraulic hoses. To ensure the integrity of your system, specify only Enerpac hydraulic hoses.

Page: **128**

RCH Series

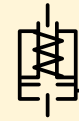

Capacity:

12 - 95 ton

Stroke:

8 - 155 mm

Center Hole Diameter:

19,5 - 79,0 mm

Maximum Operating Pressure:

700 bar

Optional Threaded Hollow Saddles

Saddle Type	Cylinder Model Number	Saddle Model Nr.	Saddle Dimensions (mm)		
			A	B	C
Threaded Hollow	RCH202, 206	HP2015	53	1" - 8	9
	RCH302, 306	HP3015	63	1¼" - 7	9
	RCH603, 606	HP5016	91	1½" - 5½	12
	RCH1003	HP10016	126	2½" - 8	13

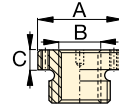

Smooth hollow saddles are standard on all RCH-models (except RCH120, RCH1211).

RCH121 and RCH1211 have a 47 mm dia. boss that protrudes 6 mm from base.

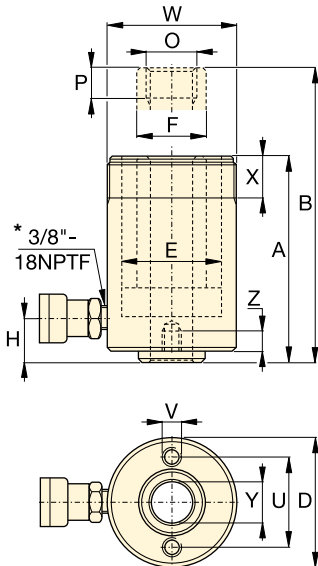

RCH120 to RCH123 models

* 1/4" NPTF for RCH120 only

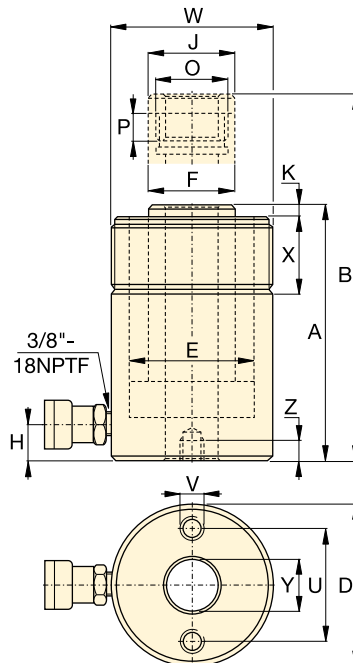

RCH202 to RCH1003 models

Base Mounting Hole Dimensions (mm)

Model Number	Bolt Circle U	Thread V	Thread Depth Z
RCH120	50,8	5/16" - 18 UNC	9,0
RCH121	-	-	-
RCH1211	-	-	-
RCH123	50,8	5/16" - 18 UNC	12,7
RCH202	82,6	3/8" - 16 UNC	9,4
RCH206	82,6	3/8" - 16 UNC	9,4
RCH302	92,2	3/8" - 16 UNC	14,0
RCH306	92,2	3/8" - 16 UNC	14,0
RCH603	130,3	1/2" - 13 UNC	14,0
RCH606	130,3	1/2" - 13 UNC	14,0
RCH1003	177,8	5/8" - 11 UNC	19,0

Coll. Height A (mm)	Ext. Height B (mm)	Outside Dia. D (mm)	Cyl. Bore Dia. E (mm)	Plgr. Dia. F (mm)	Cyl. Base to Advance Port H (mm)	Saddle Dia. J (mm)	Saddle Protrusion from Plgr. K (mm)	Plunger Internal Thread O	Plunger Thread Length P (mm)	Collar Thread W	Collar Thread Length X (mm)	Center Hole Dia. Y (mm)	Weight (kg)	Model Number
55	63	69	54,1	35,1	9	-	-	3/4" - 16 UN	16	2¾" - 16	30	19,5	1,5	RCH120
120	162	69	54,1	35,1	25	-	-	-	-	2¾" - 16	30	19,5	2,8	RCH121 *
120	162	69	54,1	35,1	25	-	-	3/4" - 16 UN	16	2¾" - 16	30	19,5	2,8	RCH1211
184	260	69	54,1	35,1	25	-	-	-	-	2¾" - 16	30	19,5	4,4	RCH123
162	211	98	73,1	54,1	19	54	9,7	19/16" - 16 UN	19	37/8" - 12	38	26,9	7,7	RCH202 *
306	461	98	73,1	54,1	25	54	9,7	19/16" - 16 UN	19	37/8" - 12	38	26,9	14,1	RCH206
178	242	114	88,9	63,5	21	63	9,0	113/16" - 16 UN	22	4½" - 12	42	33,3	10,9	RCH302 *
330	485	114	88,9	63,5	25	63	9,0	113/16" - 16 UN	22	4½" - 12	42	33,3	21,8	RCH306
247	323	159	123,9	91,9	31	91	12,0	2¾" - 16 UN	19	6¼" - 12	48	53,8	28,1	RCH603 *
323	476	159	123,9	91,9	31	91	12,0	2¾" - 16 UN	19	6¼" - 12	48	53,8	35,4	RCH606
254	330	212	165,1	127,0	38	126	12,0	4" - 16 UN	25	8¾" - 12	60	79,0	63,0	RCH1003*

▼ Shown from left to right: RRH3010, RRH1001, RRH6010



- Relief valves prevent damage in case of over-pressurisation
- Baked enamel finish for increased corrosion resistance
- Collar threads enable easy fixturing (except RRH1001 and RRH1508)
- Double-acting version for fast retraction
- Nickel-plated, floating center tube increases product life
- Hollow plunger allows for both pull and push forces
- CR400 coupler and dust cap included on all models
- Plunger wiper reduces contamination, extending cylinder life.

Versatility in Testing, Maintenance and Tensioning Applications



Ultra-Lightweight Aluminium Cylinders

If you need a higher cylinder capacity-to-weight-ratio the lightweight **RRH-Series** are the perfect choice.

Page: 18



Gauges

Minimize the risk of overloading and ensure long, dependable service from your equipment. Refer to the System Components

Section for a full range of gauges.

Page: 127



Saddles

All RRH-Series cylinders are equipped with smooth saddles. See table at next page for optional threaded saddles and all dimensional information.

Page: 37

▼ Double-acting hollow plunger cylinders are applied for bridge launching systems.



Cylinder Capacity	Stroke	Model Number	Max. Cylinder Capacity (kN)		Cylinder Effective Area (cm ²)		Oil Capacity (cm ³)	
			Advance	Retract	Advance	Retract	Advance	Retract
30	178	RRH307	326	213	46,6	30,4	829	541
	258	RRH3010	326	213	46,6	30,4	1202	784
60	89	RRH603	576	380	82,3	54,2	733	482
	166	RRH606	576	380	82,3	54,2	1366	900
	257	RRH6010	576	380	82,3	54,2	2115	1393
95	38	RRH1001	931	612	133,0	87,4	505	333
	76	RRH1003	931	612	133,0	87,4	1011	666
	153	RRH1006	931	612	133,0	87,4	2035	1337
	257	RRH10010	931	612	133,0	87,4	3420	2246
145	203	RRH1508	1429	718	204,1	102,6	4144	2083

Double-Acting, Hollow Plunger Cylinders



Hoses

Enerpac offers a complete line of high quality hydraulic hoses. To ensure the integrity of your system, specify only Enerpac hydraulic hoses.

Page: 128

Optional Threaded Hollow Saddles						
Saddle Type	Cylinder Model Number	Saddle Model Nr.	Saddle Dimensions (mm)			
			A	B	C	
Threaded Hollow	RRH307, 3010	HP3015	63	1 1/4" - 7	9	
	RRH603, 606, 6010	HP5016	91	1 5/8" - 5 1/2	12	
	RRH1001, 1003, RRH1006, 10010	HP10016	126	2 1/2" - 8	13	

Smooth hollow saddles are standard on all RRH-models.

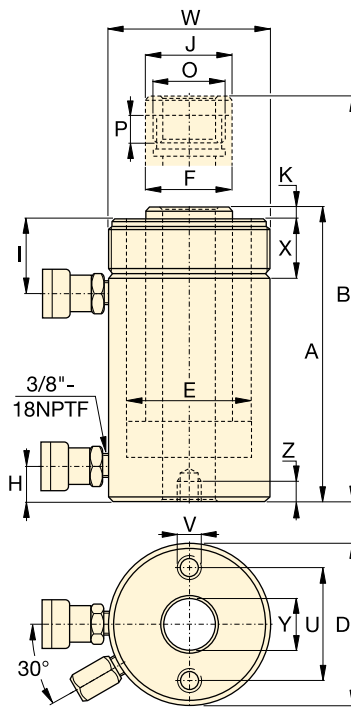

RRH Series

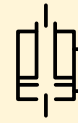

Capacity:

30 - 145 ton

Stroke:

38 - 258 mm

Center Hole Diameter:

33,3 - 79,2 mm

Maximum Operating Pressure:

700 bar



Pump Selection

A double-acting cylinder must be powered by a pump with a 4-way valve.

Page: 121

Base Mounting Hole Dimensions (mm)

Model Number	Bolt Circle	Thread	Thread Depth
	U	V	Z
RRH307	92,2	3/8" - 16	15,7
RRH3010	92,2	3/8" - 16	15,7
RRH603	130,0	1/2" - 13	14,0
RRH606	130,0	1/2" - 13	14,0
RRH6010	130,0	1/2" - 13	14,0
RRH1001	177,8	5/8" - 11	19,0
RRH1003	177,8	5/8" - 11	19,0
RRH1006	177,8	5/8" - 11	19,0
RRH10010	177,8	5/8" - 11	19,0
RRH1508	-	-	-

Coll. Height	Ext. Height	Out. Dia.	Cyl. Bore Dia.	Plgr. Dia.	Cyl. Base to Adv. Port	Cyl. Top to Return Port	Saddle Dia.	Saddle Protr. fr. Plgr.	Thread	Plunger Thread Length	Collar Thread	Collar Thread Length	Center Hole Dia.		Model Number
A	B	D	E	F	H	I	J	K	O	P	W	X	Y	(kg)	
(mm)	(mm)	(mm)	(mm)	(mm)	(mm)	(mm)	(mm)	(mm)		(mm)		(mm)	(mm)		
330	508	114	88,9	63,5	25	60	63	9	1 13/16" - 16	22	4 1/2" - 12	42	33,3	21	RRH307
431	689	114	88,9	63,5	25	60	63	9	1 13/16" - 16	22	4 1/2" - 12	42	33,3	27	RRH3010
247	336	159	123,9	91,9	31	66	91	12	2 3/4" - 16	19	6 1/4" - 12	48	53,8	28	RRH603
323	489	159	123,9	91,9	31	66	91	12	2 3/4" - 16	19	6 1/4" - 12	48	53,8	35	RRH606
438	695	159	123,9	91,9	31	66	91	12	2 3/4" - 16	19	6 1/4" - 12	48	53,8	45	RRH6010
165	203	212	165,1	127,0	38	44	126	12	4" - 16	25	-	-	79,2	33	RRH1001
254	330	212	165,1	127,0	38	85	126	12	4" - 16	25	8 3/8" - 12	60	79,2	61	RRH1003
342	495	212	165,1	127,0	38	85	126	12	4" - 16	25	8 3/8" - 12	60	79,2	79	RRH1006
460	717	212	165,1	127,0	38	85	126	12	4" - 16	25	8 3/8" - 12	60	79,2	106	RRH10010
349	552	247	190,5	152,4	38	60	127	4	4 1/4" - 12	25	-	-	79,2	111	RRH1508

▼ Shown from left to right: BRD2510, BRD96, BRD256, BRD41, BRD166



High Precision and High Cycle Performance



Speed Chart

See the Enerpac Cylinder Speed Chart in our 'Yellow Pages' to determine your approximate cylinder speed.

Page: **415**

- Designed for long life, the best choice for production applications
- Unique mounting configurations simplify fixturing
- Baked enamel finish for increased corrosion resistance
- Double-acting operation develops force in both directions, providing maximum versatility
- Plunger wiper reduces contamination, extending cylinder life
- Imperial models (RD-series) available on request.

▼ Clamping application using Enerpac BRD cylinders (with clevis eye attachments on both ends) for their high pressure capability and mounting flexibility.



Cylinder Capacity (ton)	Stroke (mm)	Model Number	Max. Cylinder Capacity (kN)		Cylinder Effective Area (cm ²)		Oil Capacity (cm ³)		Coll. Height A (mm)	Extended Height B (mm)	Body Length C (mm)	Outside Dia. D (mm)	Cylinder Bore Dia. E (mm)	Plunger Dia. F (mm)
			Advance	Retract	Advance	Retract	Advance	Retract						
4	28	BRD41	35	16	5,1	2,2	14	6	186	214	162	50	25,4	19,0
	79	BRD43	35	16	5,1	2,2	40	17	237	316	213	50	25,4	19,0
	155	BRD46	35	16	5,1	2,2	79	34	313	468	289	50	25,4	19,0
8	28	BRD91	80	44	11,4	6,3	32	18	223	251	198	63,5	38,1	25,4
	79	BRD93	80	44	11,4	6,3	90	50	274	353	249	63,5	38,1	25,4
	155	BRD96	80	44	11,4	6,3	177	98	350	505	325	63,5	38,1	25,4
	257	BRD910	80	44	11,4	6,3	293	162	452	709	427	63,5	38,1	25,4
15	159	BRD166	142	77	20,3	10,6	323	169	389	548	359	80	50,8	35,0
	260	BRD1610	142	77	20,3	10,6	528	276	491	751	461	80	50,8	35,0
23	159	BRD256	222	98	31,7	13,7	504	218	424	583	397	92	63,5	47,8
	260	BRD2510	222	98	31,7	13,7	824	356	526	786	499	92	63,5	47,8

Double-Acting, Precision Production Cylinders

▼ BRD CYLINDER ATTACHMENTS

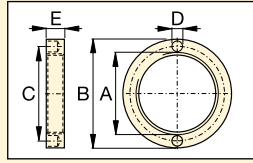

Retainer Nut
For locking foot or flange mountings. Tightens onto cylinder collar threads (Included with foot and flange mounting kits).

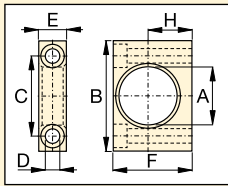

Foot Mounting
Mounts onto cylinder collar.

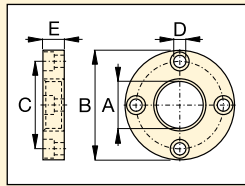

Flange Mounting
Mounts onto cylinder collar.

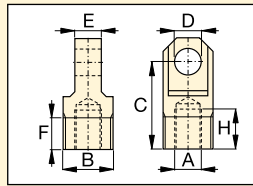

Clevis Eye
Threads onto plunger or into cylinder base.

Model Number	BRD-Cyl. (ton)	Dimensions (mm)						
		A	B	C	D	E	F	H
Foot Mounting with Retainer Nut								
BAD141	4	42,1	80	58,0	10,5	20,0	57,0	31,8
BAD171	8	56,1	105	78,0	13,5	25,0	82,5	44,5
BAD181	15	70,1	127	95,2	20,0	35,0	100,0	52,4
BAD191	23	85,1	159	117,5	26,5	45,0	125,0	63,5
Flange Mounting with Retainer Nut								
BAD142	4	42,1	98,4	78,6	11,0	19,0	-	-
BAD172	8	56,1	121	98,4	11,0	25,4	-	-
BAD182	15	70,1	143	115,9	14,0	35,0	-	-
BAD192	23	85,1	165	135,7	17,0	44,5	-	-
Retainer Nut								
BAD143	4	M42 x 1,5	57	49,5	6,3	9,5	-	-
BAD173	8	M56 x 2	75	65,5	6,7	12,7	-	-
BAD183	15	M70 x 2	92	81,0	6,7	19,0	-	-
BAD193	23	M85 x 2	108	96,5	6,7	25,4	-	-
Clevis Eye (See chart below for mounting dimensions L, L1 and M)								
BAD150	4	M16 x 1,5	M30 x 1,5	52,4	16,0	15,9	19,1	23,8
BAD151	8	M22 x 1,5	M42 x 1,5	57,1	20,0	25,4	25,4	23,8
BAD152	15	M30 x 1,5	M56 x 2	77,8	25,0	31,8	25,4	30,2
BAD153	23	M42 x 1,5	M70 x 2	77,8	32,0	38,2	25,4	27,0

BRD Series



Capacity:
4 - 23 ton

Stroke:
28 - 260 mm

Maximum Operating Pressure:
700 bar

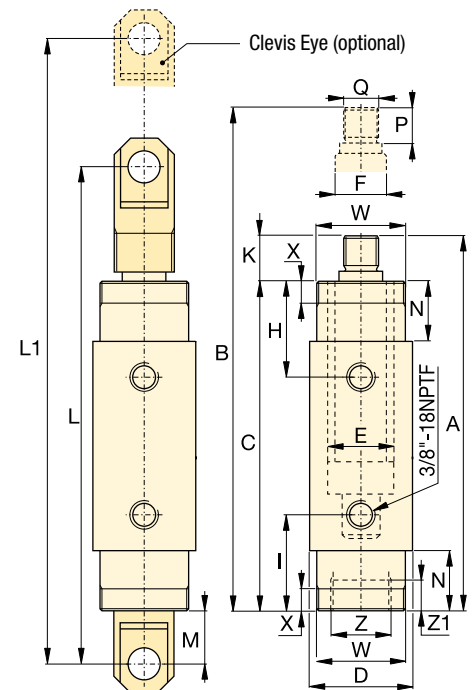

	Top to Retract Port H (mm)	Bottom to Advance Port I (mm)	Plunger Protrusion K (mm)	Clevis Eye Mounting Dimensions			Neck Length N (mm)	Plunger Thread Length P (mm)	Plunger External Thread Q (mm)	Cylinder Mounting Dimensions (mm)				Model Number	
				L (mm)	L1 (mm)	M (mm)				Collar Thread W	Collar Thread Length X	Internal Base Thread Z	Int. Base Thread Length Z1		
	47	47	24	258	286	41	29	22	M16 x 1,5	M42 x 1,5	11	M30 x 1,5	9	2,0	BRD41
	47	47	24	308	387	41	29	22	M16 x 1,5	M42 x 1,5	11	M30 x 1,5	9	2,6	BRD43
	47	47	24	385	540	41	29	22	M16 x 1,5	M42 x 1,5	11	M30 x 1,5	9	3,6	BRD46
	57	57	25	295	323	38	38	22	M22 x 1,5	M56 x 2	14	M42 x 1,5	14	3,0	BRD91
	57	57	25	346	425	38	38	22	M22 x 1,5	M56 x 2	14	M42 x 1,5	14	4,2	BRD93
	57	57	25	422	577	38	38	22	M22 x 1,5	M56 x 2	14	M42 x 1,5	14	5,6	BRD96
	57	57	25	524	781	38	38	22	M22 x 1,5	M56 x 2	14	M42 x 1,5	14	7,3	BRD910
	73	73	30	492	651	52	54	28	M30 x 1,5	M70 x 2	22	M56 x 2	24	10,2	BRD166
	73	73	30	593	853	52	54	28	M30 x 1,5	M70 x 2	22	M56 x 2	24	14,5	BRD1610
	89	89	27	524	683	53	70	25	M42 x 1,5	M85 x 2	29	M70 x 2	26	16,0	BRD256
	89	89	27	626	886	53	70	25	M42 x 1,5	M85 x 2	29	M70 x 2	26	20,3	BRD2510

RR-Series, Double-Acting Cylinders

ENERPAC 

▼ Shown from left to right: RR10013, RR1502, RR20013, RR1010, RR7513



- Collar threads, plunger threads and base mounting holes for easy fixturing (on most models)
- Baked enamel finish for increased corrosion resistance
- Removable hardened saddles protect plunger during lifting and pressing
- Built-in safety valve prevents accidental over-pressurization
- CR400 couplers and dust caps included on all models
- Plunger wiper reduces contamination, extending cylinder life.

▼ A lateral bridge slide method was utilized to slide the new bridge into position. Two RR-Series double acting hydraulic cylinders with ZU4-Series electric pumps were used to push the bridge into position over PTFE sliding elements.



Most Versatile Performers

Rugged enough for the toughest job site uses and precision designed for high-cycle industrial uses.



Optional Snap-in Saddles

Optional snap-in saddles for RR-Series double-acting cylinders up to 75 ton.

Page: **41**



Optimum Performance

Enerpac's range of Z-Class electric pumps, fitted with manual or solenoid operated 4-way valves, offer optimum combinations with RR-Series cylinders.

Page: **96**

▼ RR-cylinders provide power and precision in a special hydraulic press.



Double-Acting Long Stroke Cylinders



Pump Selection

A double-acting cylinder must be powered by a pump with a 4-way valve.

Page: 75

▼ QUICK SELECTION CHART

For complete technical information see next page.

Cylinder Capacity ton (kN)	Stroke (mm)	Model Number	Cylinder Effective Area (cm ²)		Oil Capacity (cm ³)		Coll. Height (mm)
			Push	Pull	Push	Pull	
10 (101)	254	RR1010	14,5	4,8	368	122	409
	305	RR1012	14,5	4,8	442	147	457
30 (295)	209	RR308	42,1	19,1	879	400	394
	368	RR3014	42,1	19,1	1549	703	549
50 (498)	156	RR506	71,2	21,5	1111	335	331
	334	RR5013	71,2	21,5	2378	718	509
	511	RR5020	71,2	21,5	3638	1099	733
75 (718)	156	RR756	102,6	31,4	1601	490	347
	333	RR7513	102,6	31,4	3417	1046	525
95 (933)	168	RR1006	133,3	62,2	2238	1045	357
	333	RR10013	133,3	62,2	4439	2071	524
	460	RR10018	133,3	62,2	6132	2861	687
140 (1386)	57	RR1502	198,1	95,4	1129	544	183
	156	RR1506	198,1	95,4	3090	1488	385
	333	RR15013	198,1	95,4	6597	3177	582
	815	RR15032	198,1	95,4	16.145	7775	1116
200 (1995)	152	RR2006	285,0	145,3	4332	2209	430
	330	RR20013	285,0	145,3	9405	4795	608
	457	RR20018	285,0	145,3	13025	6640	765
	610	RR20024	285,0	145,3	17.385	8863	917
	914	RR20036	285,0	145,3	26.049	13.280	1222
1219	RR20048	285,0	145,3	34.741	17.712	1527	
325 (3201)	153	RR3006	457,3	243,2	6997	3721	485
	305	RR30012	457,3	243,2	13947	7418	638
	457	RR30018	457,3	243,2	20.889	11.114	790
	609	RR30024	457,3	243,2	27.850	14.811	943
	915	RR30036	457,3	243,2	41.843	22.253	1247
	1219	RR30048	457,3	243,2	55745	29646	1552
440 (4292)	152	RR4006	613,1	328,1	9319	4987	538
	305	RR40012	613,1	328,1	18.700	10.007	690
	457	RR40018	613,1	328,1	28.018	14.995	843
	610	RR40024	613,1	328,1	37.400	20.014	995
	914	RR40036	613,1	328,1	56.037	29.988	1300
	1219	RR40048	613,1	328,1	74.737	39.996	1605
520 (5108)	153	RR5006	729,7	405,4	11.164	6203	577
	305	RR50012	729,7	405,4	22.256	12.365	730
	457	RR50018	729,7	405,4	33.347	18.526	882
	609	RR50024	729,7	405,4	44.440	24.689	1035
	915	RR50036	729,7	405,4	66.768	36.973	1339
	1219	RR50048	729,7	405,4	88.951	49.418	1644

RR Series



Capacity:

10 - 520 ton

Stroke:

57 - 1219 mm

Maximum Operating Pressure:

700 bar

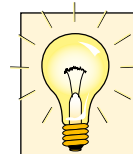

Enerpac HCR-Series

If your application does not require high cycle, Enerpac **HCR-Series** cylinders may be the right alternative.

Page: 52



Speed Chart

See the Enerpac Cylinder Speed Chart in our 'Yellow Pages' to determine your approximate cylinder speed.

Page: 415



Optional Snap-in Saddles

Optional snap-in saddles for RR-Series double-acting cylinders:

Saddle Type	Cylinder Model	Saddle Model Number
Flat	RR10	A102F
	RR10	CATS12
Tilt	RR30	CATS52
	RR50	CATS100
	RR75	CATS100

Standard Saddles:

Grooved	Cylinder Model	Saddle Model Number
Grooved	RR10	A102G
	RR30	A252G

For additional information on saddles:

Page: 10

RR-Series, Double-Acting Cylinders

ENERPAC 

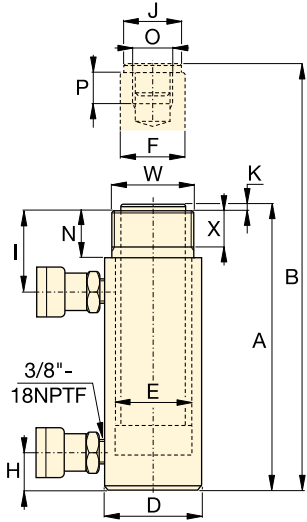

RR1010 - RR3014

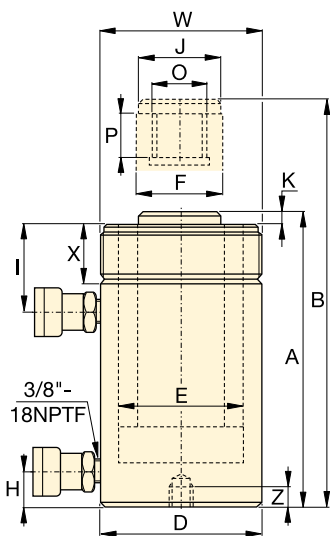

RR506 - RR50048

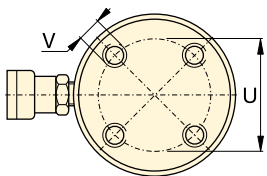

RR1006 - RR30048

No mounting holes on:
RR506, 5013
RR756, 7513
RR1502, 15032

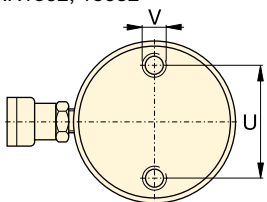

RR4006 - RR50048

Base mounting hole location is for reference only, as it is affected by assembly.



Cylinder retract capacity for certain RR cylinders may be less than theoretical values, as a result of reduced relief valve pressure settings:

RR308/3014: 275 bar
RR506/5013/5020: 480 bar
RR756/7513: 495 bar

◀ For full features see previous page.

Cylinder Capacity	Stroke (mm)	Model Number	Max. Cylinder Capacity (kN)		Cylinder Effective Area (cm ²)		Oil Capacity (cm ³)		Coll. Height	Ext. Height	Outside Dia.
			Push	Pull	Push	Pull	Push	Pull	A (mm)	B (mm)	D (mm)
10	254	RR1010 *	101	33	14,5	4,8	368	122	409	663	73
	305	RR1012 *	101	33	14,5	4,8	442	147	457	762	73
30	209	RR308 *	295	53	42,1	19,1	879	400	394	603	101
	368	RR3014 *	295	53	42,1	19,1	1549	703	549	917	101
50	156	RR506	498	103	71,2	21,5	1111	335	331	487	127
	334	RR5013	498	103	71,2	21,5	2378	718	509	843	127
	511	RR5020	498	103	71,2	21,5	3638	1099	733	1244	127
75	156	RR756	718	156	102,6	31,4	1601	490	347	503	146
	333	RR7513	718	156	102,6	31,4	3417	1046	525	858	146
95	168	RR1006	933	435	133,3	62,2	2238	1045	357	525	177
	333	RR10013	933	435	133,3	62,2	4439	2071	524	857	177
	460	RR10018	933	435	133,3	62,2	6132	2861	687	1147	177
140	57	RR1502	1386	668	198,1	95,4	1129	544	183	240	203
	156	RR1506	1386	668	198,1	95,4	3090	1488	385	541	203
	333	RR15013	1386	668	198,1	95,4	6597	3177	582	915	203
	815	RR15032	1386	668	198,1	95,4	16.145	7775	1116	1931	203
200	152	RR2006	1995	1017	285,0	145,3	4332	2209	430	582	247
	330	RR20013	1995	1017	285,0	145,3	9405	4795	608	938	247
	457	RR20018	1995	1017	285,0	145,3	13.025	6640	765	1222	247
	610	RR20024	1995	1017	285,0	145,3	17.385	8863	917	1527	247
	914	RR20036	1995	1017	285,0	145,3	26.049	13.280	1222	2136	247
	1219	RR20048	1995	1017	285,0	145,3	34.741	17.712	1527	2746	247
325	153	RR3006	3201	1703	457,3	243,2	6997	3721	485	638	311
	305	RR30012	3201	1703	457,3	243,2	13.947	7418	638	943	311
	457	RR30018	3201	1703	457,3	243,2	20.889	11.114	790	1247	311
	609	RR30024	3201	1703	457,3	243,2	27.850	14.811	943	1552	311
	915	RR30036	3201	1703	457,3	243,2	41.843	22.253	1247	2162	311
	1219	RR30048	3201	1703	457,3	243,2	55.745	29.646	1552	2771	311
440	152	RR4006	4292	2297	613,1	328,1	9319	4987	538	690	358
	305	RR40012	4292	2297	613,1	328,1	18.700	10.007	690	995	358
	457	RR40018	4292	2297	613,1	328,1	28.018	14.995	843	1300	358
	610	RR40024	4292	2297	613,1	328,1	37.400	20.014	995	1605	358
	914	RR40036	4292	2297	613,1	328,1	56.037	29.988	1300	2214	358
	1219	RR40048	4292	2297	613,1	328,1	74.737	39.996	1605	2824	358
520	153	RR5006	5108	2838	729,7	405,4	11164	6203	577	730	397
	305	RR50012	5108	2838	729,7	405,4	22.256	12.365	730	1035	397
	457	RR50018	5108	2838	729,7	405,4	33.347	18.526	882	1339	397
	609	RR50024	5108	2838	729,7	405,4	44.440	24.689	1035	1644	397
	915	RR50036	5108	2838	729,7	405,4	66.768	36.973	1339	2254	397
	1219	RR50048	5108	2838	729,7	405,4	88.951	49.418	1644	2863	397

* For RR1010 and RR1012: N = 32 mm; for RR308 and RR3014: N = 55 mm.

Double-Acting Long Stroke Cylinders

Capacity:

10 - 520 ton

Stroke:

57 - 1219 mm

Maximum Operating Pressure:

700 bar

**RR
Series**



Cyl. Bore Dia. E (mm)	Plgr. Dia. F (mm)	Base to Adv. Port H (mm)	Top to Ret. Port I (mm)	Saddle Dia. J (mm)	Saddle Protr. fr. Plgr. K (mm)	Plunger Internal Thread O	Plunger Thread Length P (mm)	Base Mounting Holes			Collar Thread W	Collar Thread Length X (mm)	Model Number	
								Bolt Circle U (mm)	Thread V	Thread Depth Z (mm)				
42,9	34,9	36	57	35	6	1" - 8	25	-	-	-	2 1/4" - 14	26	12	RR1010*
42,9	34,9	36	57	35	6	1" - 8	25	-	-	-	2 1/4" - 14	26	14	RR1012*
73,2	54,1	39	81	50	10	1 1/2" - 16	25	-	-	-	3 5/16" - 12	49	18	RR308*
73,2	54,1	39	81	50	10	1 1/2" - 16	25	-	-	-	3 5/16" - 12	49	29	RR3014*
95,2	79,5	28	76	71	2	1" - 12	25	-	-	-	5" - 12	44	30	RR506
95,2	79,5	28	76	71	2	1" - 12	25	-	-	-	5" - 12	44	52	RR5013
95,2	79,5	57	76	71	2	1" - 12	25	76	1/2" - 13	25	5" - 12	44	68	RR5020
114,3	95,2	30	76	71	6	1" - 12	28	-	-	-	5 3/4" - 12	50	41	RR756
114,3	95,2	30	81	71	6	1" - 12	28	-	-	-	5 3/4" - 12	50	68	RR7513
130,3	95,2	38	71	76	3	1 3/4" - 12	35	139	3/4" - 10	25	6 7/8" - 12	50	61	RR1006
130,3	95,2	38	71	76	3	1 3/4" - 12	35	139	3/4" - 10	25	6 7/8" - 12	50	93	RR10013
130,3	95,2	41	92	76	3	1 3/4" - 12	35	139	3/4" - 10	25	6 7/8" - 12	50	117	RR10018
158,8	114,3	22	66	95	19	-	-	-	-	-	-	-	49	RR1502
158,8	114,3	49	84	114	19	3 3/8" - 16	35	158	3/4" - 16	28	8" - 12	55	93	RR1506
158,8	114,3	49	84	114	19	3 3/8" - 16	35	158	3/4" - 16	28	8" - 12	55	124	RR15013
158,8	114,3	76	88	114	19	3 3/8" - 16	35	-	-	-	8" - 12	55	238	RR15032
190,5	133,4	57	96	133	22	-	-	127	1" - 8	25	-	-	147	RR2006
190,5	133,4	57	96	133	22	2 1/2" - 12	63	127	1" - 8	25	9 3/4" - 12	54	199	RR20013
190,5	133,4	85	101	133	22	2 1/2" - 12	63	127	1" - 8	25	9 3/4" - 12	54	204	RR20018
190,5	133,4	85	101	133	22	2 1/2" - 12	63	127	1" - 8	25	9 3/4" - 12	54	279	RR20024
190,5	133,4	85	101	133	22	2 1/2" - 12	63	127	1" - 8	25	9 3/4" - 12	54	383	RR20036
190,5	133,4	85	101	133	22	2 1/2" - 12	63	127	1" - 8	25	9 3/4" - 12	54	483	RR20048
241,3	165,1	88	114	165	28	2 1/2" - 12	82	158	1 1/4" - 7	44	12 1/4" - 12	58	200	RR3006
241,3	165,1	88	114	165	28	2 1/2" - 12	82	158	1 1/4" - 7	44	12 1/4" - 12	58	312	RR30012
241,3	165,1	88	114	165	28	2 1/2" - 12	82	158	1 1/4" - 7	44	12 1/4" - 12	58	385	RR30018
241,3	165,1	88	114	165	28	2 1/2" - 12	82	158	1 1/4" - 7	44	12 1/4" - 12	58	469	RR30024
241,3	165,1	88	114	165	28	2 1/2" - 12	82	158	1 1/4" - 7	44	12 1/4" - 12	58	628	RR30036
241,3	165,1	88	114	165	28	2 1/2" - 12	82	158	1 1/4" - 7	44	12 1/4" - 12	58	780	RR30048
279,4	190,5	108	133	190	28	3" - 12	95	203	1 1/2" - 6	50	14 1/8" - 8	65	303	RR4006
279,4	190,5	108	133	190	28	3" - 12	95	203	1 1/2" - 6	50	14 1/8" - 8	65	399	RR40012
279,4	190,5	108	133	190	28	3" - 12	95	203	1 1/2" - 6	50	14 1/8" - 8	65	453	RR40018
279,4	190,5	108	133	190	28	3" - 12	95	203	1 1/2" - 6	50	14 1/8" - 8	65	597	RR40024
279,4	190,5	108	133	190	28	3" - 12	95	203	1 1/2" - 6	50	14 1/8" - 8	65	792	RR40036
279,4	190,5	108	133	190	28	3" - 12	95	203	1 1/2" - 6	50	14 1/8" - 8	65	980	RR40048
304,8	203,2	120	152	203	28	3 1/4" - 12	108	203	1 3/4" - 5	57	15 5/8" - 8	79	432	RR5006
304,8	203,2	120	152	203	28	3 1/4" - 12	108	203	1 3/4" - 5	57	15 5/8" - 8	79	589	RR50012
304,8	203,2	120	152	203	28	3 1/4" - 12	108	203	1 3/4" - 5	57	15 5/8" - 8	79	680	RR50018
304,8	203,2	120	152	203	28	3 1/4" - 12	108	203	1 3/4" - 5	57	15 5/8" - 8	79	816	RR50024
304,8	203,2	120	152	203	28	3 1/4" - 12	108	203	1 3/4" - 5	57	15 5/8" - 8	79	1002	RR50036
304,8	203,2	120	152	203	28	3 1/4" - 12	108	203	1 3/4" - 5	57	15 5/8" - 8	79	1224	RR50048

▼ HCL2006, HCG2002, HCR2006



Reaching the Summit Edition:

- Nitrocarburized hardened surfaces offers improved protection against side-load scoring and cyclic wear
- Weather protected, inside and out
- Low-friction locking rings spin easy, save time and effort ¹⁾
- State of the art bearing materials reduce wear and avoid bore damage even in high side-load conditions.

Low wear, high pressure seals

- Improved seal design and material selection increases seal performance even in harsh conditions
- Low friction for faster retraction, longer life.

Versatile

- Over 220 models in 5 configurations ¹⁾
- Certified lifting eyes, base mounting holes and collar threads are included for secure handling and cylinder mounting ¹⁾

¹⁾ See specific models technical data for more information.

Highest Level of Durability



The Summit Edition

Innovation is at the heart of the new Summit Edition cylinders, delivering the high quality construction you expect from Enerpac. The design and durability add safety and reliability to your job.

- Plunger support bearing adds support for eccentric loads ²⁾
- Nitrocarburization surface treatment for improved wear resistance and corrosion protection
- Low wear, high pressure seals provide longer service life.

²⁾ Eccentric load (or "side-load") is inevitable in heavy lifting. Our unique Summit Edition features provide the ultimate protection against side-load. Increased bearing surface maintains stability and nitrocarburization treatment prevents scoring on the inside of the cylinder. Side-load poses a real problem.... our new cylinder features are the solution!

▼ Bridge lifting and launching system. The load is balanced on groups of lock nut cylinders. The hydraulic movements are synchronised using the Enerpac PLC-controlled synchronous lift system.





High Tonnage Cylinders

The Enerpac High Tonnage Cylinders are particularly suitable for (multipoint) lifting applications.

HCG, HCR, HCL-Series Cylinders

- 50 - 1000 ton lifting capacity
- 50 - 300 mm stroke

HCG-Series - single-acting

- gravity return
- stop ring to prevent plunger blow-out
- designed to withstand up to 10% side-load of maximum capacity.

HCR-Series - double-acting

- hydraulic advance and retract for controlled movement
- designed to withstand up to 10% side-load of maximum capacity.

HCL-Series - lock nut, single-acting

- gravity return
- lock nut for mechanical load holding
- overflow port to prevent plunger blow out
- designed to withstand 10% side-load up to 90% of maximum stroke.

HCRL-Series - lock nut, double-acting

- hydraulic advance and retract
- designed to withstand up to 10% side-load of maximum capacity
- integrated tilt saddle
- lock nut for mechanical load holding
- 50 - 300 ton lifting capacity
- 150 - 300 mm stroke

LPL-Series - lock nut, low height, single-acting (see page 24)

- 60 - 500 ton lifting capacity;
- 45 - 50 mm lifting stroke
- integrated tilt saddle
- gravity return
- lock nut for mechanical load holding
- 5-10% side-load of maximum capacity.

In combination with our state of the art power packs, you will have a world class hydraulic system to perform the most challenging lifting jobs in a safe and professional manner. See **page 75** for more information on our pump offering.

Page: 46

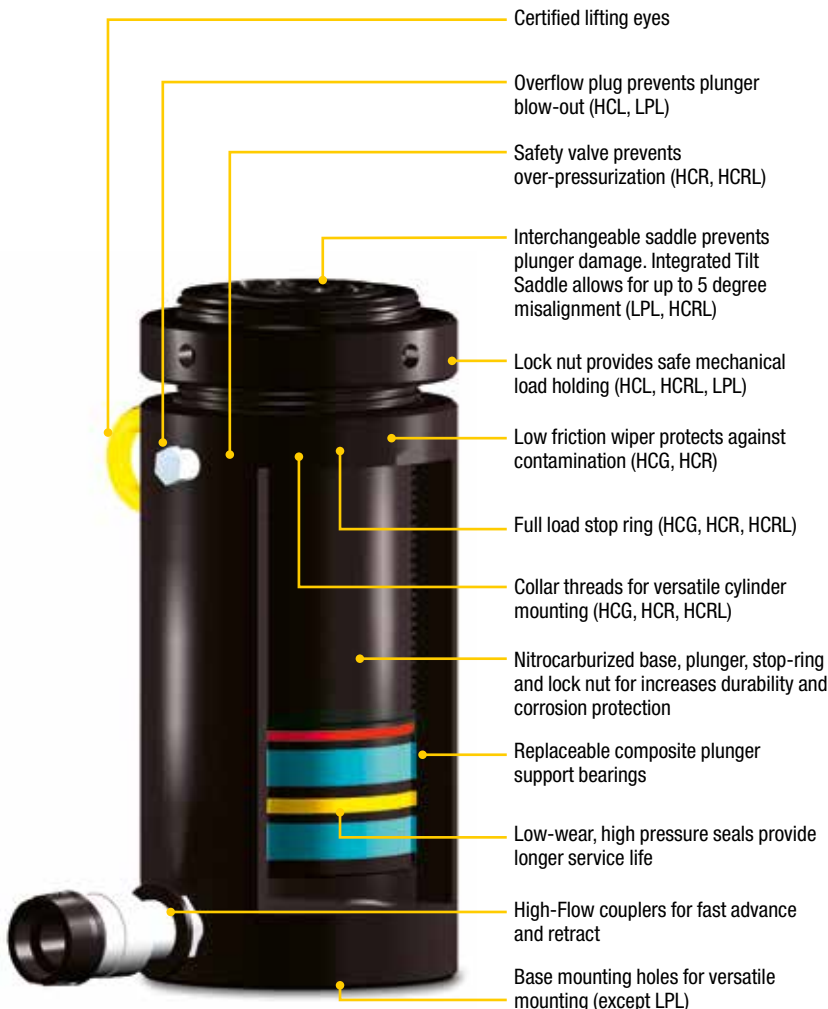

HCG HCR HCL HCRL Series



Capacity:

50 - 1000 ton

Stroke:

50 - 300 mm

Maximum Operating Pressure:

700 bar



Assisted Return Pumps

Enerpac HCG, HCL and LPL-Series cylinders are hydraulic advance and gravity return. To improve productivity and plunger retraction Enerpac offers assisted return on ZU4 and ZE-Series pumps featuring **Enerpac Venturi valve technology**, specifically to facilitate the faster return of single-acting, spring and gravity return cylinders. See enerpac.com for details.

Page: 100



Split-Flow Pumps

SFP-Series pumps with multiple outlets with equal oil flow. For lifting and lowering applications on multiple points these pumps are a far better alternative than using separately operated pumps.

Page: 344



Synchronous Lifting Systems

EVO-Series pumps the multi-functional lifting system and multiple lift point capabilities.

Page: 350



QUICK SELECTION

Cylinder Capacity ton	Stroke (mm)	Maximum Cylinder Capacity at 700 bar ton (kN)	HCG-Series		HCR-Series		HCL-Series		HCRL-Series *	
			Model Number Single-Acting <i>Page: 48</i>	Collapsed Height (mm)	Model Number Double-Acting <i>Page: 52</i>	Collapsed Height (mm)	Model Number Single-Acting With Lock Nut <i>Page: 56</i>	Collapsed Height (mm)	Model Number Double-Acting With Lock Nut <i>Page: 60</i>	Collapsed Height (mm)
50	50	56 (550)	HCG502	183	HCR502	183	HCL502	164	—	—
	100		HCG504	233	HCR504	233	HCL504	214	—	—
	150		HCG506	283	HCR506	283	HCL506	264	HCRL506	310
	200		HCG508	346	HCR508	346	HCL508	314	HCRL508	377
	250		HCG5010	396	HCR5010	396	HCL5010	364	HCRL5010	427
	300		HCG5012	446	HCR5012	446	HCL5012	414	HCRL5012	477
100	50	102 (1002)	HCG1002	202	HCR1002	202	HCL1002	187	—	—
	100		HCG1004	252	HCR1004	252	HCL1004	237	—	—
	150		HCG1006	302	HCR1006	302	HCL1006	287	HCRL1006	346
	200		HCG1008	379	HCR1008	379	HCL1008	337	HCRL1008	421
	250		HCG10010	429	HCR10010	429	HCL10010	387	HCRL10010	471
	300		HCG10012	479	HCR10012	479	HCL10012	437	HCRL10012	521
150	50	153 (1497)	HCG1502	220	HCR1502	220	HCL1502	209	—	—
	100		HCG1504	270	HCR1504	270	HCL1504	259	—	—
	150		HCG1506	320	HCR1506	320	HCL1506	309	HCRL1506	359
	200		HCG1508	397	HCR1508	397	HCL1508	359	HCRL1508	434
	250		HCG15010	447	HCR15010	447	HCL15010	409	HCRL15010	484
	300		HCG15012	497	HCR15012	497	HCL15012	459	HCRL15012	534
200	50	202 (1985)	HCG2002	231	HCR2002	231	HCL2002	238	—	—
	100		HCG2004	281	HCR2004	281	HCL2004	288	—	—
	150		HCG2006	331	HCR2006	331	HCL2006	338	HCRL2006	399
	200		HCG2008	408	HCR2008	408	HCL2008	388	HCRL2008	469
	250		HCG20010	458	HCR20010	458	HCL20010	438	HCRL20010	519
	300		HCG20012	508	HCR20012	508	HCL20012	488	HCRL20012	569
250	50	259 (2541)	HCG2502	241	HCR2502	241	HCL2502	249	—	—
	100		HCG2504	291	HCR2504	291	HCL2504	299	—	—
	150		HCG2506	341	HCR2506	341	HCL2506	349	HCRL2506	416
	200		HCG2508	431	HCR2508	431	HCL2508	399	HCRL2508	491
	250		HCG25010	481	HCR25010	481	HCL25010	449	HCRL25010	541
	300		HCG25012	531	HCR25012	531	HCL25012	499	HCRL25012	591
300	50	310 (3036)	HCG3002	296	HCR3002	296	HCL3002	278	—	—
	100		HCG3004	346	HCR3004	346	HCL3004	328	—	—
	150		HCG3006	396	HCR3006	396	HCL3006	378	HCRL3006	421
	200		HCG3008	446	HCR3008	446	HCL3008	428	HCRL3008	496
	250		HCG30010	496	HCR30010	496	HCL30010	478	HCRL30010	546
	300		HCG30012	546	HCR30012	546	HCL30012	528	HCRL30012	596

* See page 60 for HCRL-cylinder maximum capacity.

Enerpac High Tonnage Cylinders

Capacity:
50 - 1000 ton

Stroke:
50 - 300 mm

Maximum Operating Pressure:
700 bar

**HCG
HCR
HCL
HCRL
Series**



QUICK SELECTION

Cylinder Capacity ton	Stroke (mm)	Maximum Cylinder Capacity at 700 bar ton (kN)	HCG-Series		HCR-Series		HCL-Series	
			Model Number Single-Acting <i>Page: 50</i>	Collapsed Height (mm)	Model Number Double-Acting <i>Page: 54</i>	Collapsed Height (mm)	Model Number Single-Acting With Lock Nut <i>Page: 58</i>	Collapsed Height (mm)
400	50	409 (4008)	HCG4002	321	HCR4002	321	HCL4002	317
	100		HCG4004	371	HCR4004	371	HCL4004	367
	150		HCG4006	421	HCR4006	421	HCL4006	417
	200		HCG4008	471	HCR4008	471	HCL4008	467
	250		HCG40010	521	HCR40010	521	HCL40010	517
	300		HCG40012	571	HCR40012	571	HCL40012	567
500	50	522 (5114)	HCG5002	344	HCR5002	344	HCL5002	357
	100		HCG5004	394	HCR5004	394	HCL5004	407
	150		HCG5006	444	HCR5006	444	HCL5006	457
	200		HCG5008	494	HCR5008	494	HCL5008	507
	250		HCG50010	544	HCR50010	544	HCL50010	557
	300		HCG50012	594	HCR50012	594	HCL50012	607
600	50	611 (5987)	HCG6002	352	HCR6002	352	HCL6002	380
	100		HCG6004	402	HCR6004	402	HCL6004	430
	150		HCG6006	452	HCR6006	452	HCL6006	480
	200		HCG6008	502	HCR6008	502	HCL6008	530
	250		HCG60010	552	HCR60010	552	HCL60010	580
	300		HCG60012	602	HCR60012	602	HCL60012	630
800	50	831 (8149)	HCG8002	404	HCR8002	404	HCL8002	430
	100		HCG8004	454	HCR8004	454	HCL8004	480
	150		HCG8006	504	HCR8006	504	HCL8006	530
	200		HCG8008	554	HCR8008	554	HCL8008	580
	250		HCG80010	604	HCR80010	604	HCL80010	630
	300		HCG80012	654	HCR80012	654	HCL80012	680
1000	50	1085 (10.644)	HCG10002	442	HCR10002	442	HCL10002	484
	100		HCG10004	492	HCR10004	492	HCL10004	534
	150		HCG10006	542	HCR10006	542	HCL10006	584
	200		HCG10008	592	HCR10008	592	HCL10008	634
	250		HCG100010	642	HCR100010	642	HCL100010	684
	300		HCG100012	692	HCR100012	692	HCL100012	734

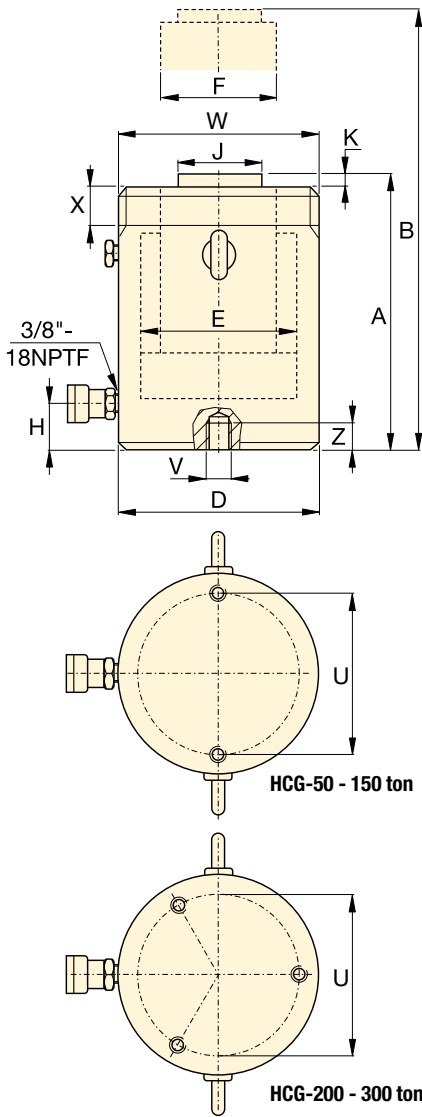

HCG-50 - 150 ton

HCG-200 - 300 ton

Collar Thread * (mm)		
Model / Capacity ton	Thread Size	Thread Length
	W	X
HCG50	M130 x 2	30
HCG100	M175 x 3	46
HCG150	M215 x 3	55
HCG200	M250 x 3	63
HCG250	M280 x 3	64
HCG300*	M305 x 3	73

* Standard collar thread up to 250 ton models. Collar thread is optional on 300 ton models and higher. For collar thread on cylinder add suffix "E002" to model number. **Example: HCG300E002**
The collar thread length is designed for the full rated cylinder capacity.

Base Mounting Holes (mm)					
Model / Capacity ton	Bolt Circle	Thread Size	Minimum Thread Depth	Number of Holes	Angle from Coupler
	U	V	Z		
HCG50	105	M12 x 1,75	22	2	90°
HCG100	150	M12 x 1,75	22	2	90°
HCG150	185	M12 x 1,75	22	2	90°
HCG200	215	M12 x 1,75	22	3	60°
HCG250	245	M12 x 1,75	22	3	60°
HCG300	260	M16 x 2	25	3	60°

HCG-Series, Single-Acting, Gravity Return Cylinders

- Hardened surface resists side-loading and cyclic wear
- Designed to withstand 10% side-load of maximum capacity ¹⁾
- Stop ring to prevent plunger blow-out
- Weather protected, inside and out
- Upper and lower replaceable bearings enclose the cylinder plunger for support throughout the stroke
- Certified lifting eyes, base mounting holes and collar threads.
- Standard collar thread up to 250 ton models. Collar thread is optional on 300 ton models and higher.

SELECTION CHART 50 - 300 TON HCG-MODELS

For 400 - 1000 ton models, see pages 50-51.

For full product features see pages 44-45.

Cylinder Capacity	Stroke	Model Number	Maximum Cylinder Capacity at 700 bar ton (kN)	Cylinder Effective Area	Oil Capacity	Collapsed Height
ton	(mm)			(cm ²)	(cm ³)	A (mm)
50	50	HCG502	56 (550)	78,5	393	183
	100	HCG504			785	233
	150	HCG506 ¹⁾			1178	283
	200	HCG508			1571	346
	250	HCG5010			1963	396
	300	HCG5012 ¹⁾			2356	446
100	50	HCG1002	102 (1002)	143,1	716	202
	100	HCG1004			1431	252
	150	HCG1006			2147	302
	200	HCG1008			2863	379
	250	HCG10010			3578	429
	300	HCG10012			4294	479
150	50	HCG1502	153 (1497)	213,8	1069	220
	100	HCG1504			2138	270
	150	HCG1506			3207	320
	200	HCG1508			4276	397
	250	HCG15010			5346	447
	300	HCG15012			6415	497
200	50	HCG2002	202 (1985)	283,5	1418	231
	100	HCG2004			2835	281
	150	HCG2006			4253	331
	200	HCG2008			5671	408
	250	HCG20010			7088	458
	300	HCG20012			8506	508
250	50	HCG2502	259 (2541)	363,1	1815	241
	100	HCG2504			3631	291
	150	HCG2506			5446	341
	200	HCG2508			7261	431
	250	HCG25010			9076	481
	300	HCG25012			10.892	531
300	50	HCG3002	310 (3036)	433,7	2169	296
	100	HCG3004			4337	346
	150	HCG3006			6506	396
	200	HCG3008			8675	446
	250	HCG30010			10.843	496
	300	HCG30012			13.012	546

¹⁾ HCG506 and HCG5012: 7% side-load of maximum capacity.

Single-Acting, High Tonnage Cylinders

Capacity:
50 - 300 ton

Stroke:
50 - 300 mm

Maximum Operating Pressure:
700 bar

HCG Series

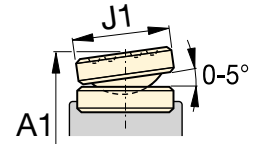

CATS-Series Tilt Saddle

Extended Height	Outside Diameter	Cylinder Bore Diameter	Plunger Diameter	Base to Advance Port	Standard Saddle Diameter	Saddle Protrusion from Plunger		Model Number
B (mm)	D (mm)	E (mm)	F (mm)	H (mm)	J (mm)	K (mm)	(kg)	
233	130	100	70	38	50	3	17	HCG502
333							20	HCG504
433							24	HCG506 ¹⁾
546							29	HCG508
646							32	HCG5010
746							36	HCG5012 ¹⁾
252	175	135	95	38	75	3	33	HCG1002
352							40	HCG1004
452							46	HCG1006
579							58	HCG1008
679							65	HCG10010
779							71	HCG10012
270	215	165	120	41	94	3	56	HCG1502
370							66	HCG1504
470							76	HCG1506
597							94	HCG1508
697							104	HCG15010
797							115	HCG15012
281	250	190	140	47	113	3	81	HCG2002
381							95	HCG2004
481							109	HCG2006
608							136	HCG2008
708							150	HCG20010
808							164	HCG20012
291	280	215	170	53	140	4	107	HCG2502
391							125	HCG2504
491							144	HCG2506
631							182	HCG2508
731							201	HCG25010
831							219	HCG25012
346	305	235	200	58	140	4	158	HCG3002
446							182	HCG3004
546							206	HCG3006
646							230	HCG3008
746							254	HCG30010
846							278	HCG30012

Optional Tilt Saddle		
Saddle Diameter J1 (mm)	Collapsed Height ²⁾ A1 (mm)	Saddle Model Number
71	197	CATS50
	247	
	297	
	360	
	410	
	460	
71	212	CATS101
	262	
	312	
	389	
	439	
	489	
97	239	CATS150
	289	
	339	
	416	
	466	
	516	
126	249	CATS200
	299	
	349	
	426	
	476	
	526	
175	280	CATS300
	330	
	380	
	470	
	520	
	570	
175	335	CATS300
	385	
	435	
	485	
	535	
	585	

²⁾ A1 = Collapsed height including CATS-Series tilt saddle.

HCG-Series, Single-Acting, Gravity Return Cylinders

- Hardened surface resists side-loading and cyclic wear
- Designed to withstand 10% side-load of maximum capacity
- Stop ring to prevent plunger blow-out
- Weather protected, inside and out
- Upper and lower replaceable bearings enclose the cylinder plunger for support throughout the stroke
- Certified lifting eyes, base mounting holes
- Optional collar threads on 300 ton models and higher capacities.

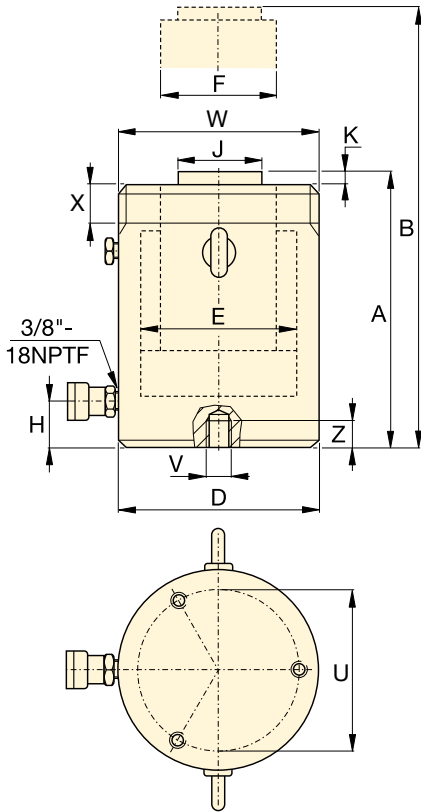

Optional Collar Thread (mm)		
Model / Capacity ton	Thread Size	Thread Length
	W	X
HCG400	M350 x 3	83
HCG500	M400 x 4	90
HCG600	M430 x 4	100
HCG800	M505 x 5	122
HCG1000	M570 x 5	137

Collar thread is optional on 300 ton models and higher. For collar thread on cylinder add suffix "E002" to model number. Example: **HCG400E002**

The collar thread length is designed for the full rated cylinder capacity.

Base Mounting Holes (mm)					
Model / Capacity ton	Bolt Circle	Thread Size	Minimum Thread Depth	Number of Holes	Angle from Coupler
	U	V	Z		
HCG400	300	M16 x 2	25	3	60°
HCG500	340	M24 x 3	36	3	60°
HCG600	370	M24 x 3	36	3	60°
HCG800	440	M24 x 3	36	3	60°
HCG1000	500	M24 x 3	36	3	60°

SELECTION CHART 400 - 1000 TON HCG-MODELS

For 50 - 300 ton models, see pages 48-49.

For full product features see pages 44-45.

Cylinder Capacity ton	Stroke (mm)	Model Number	Maximum Cylinder Capacity at 700 bar ton (kN)	Cylinder Effective Area (cm ²)	Oil Capacity (cm ³)	Collapsed Height A (mm)
400	50	HCG4002	409 (4008)	572,6	2863	321
	100	HCG4004			5726	371
	150	HCG4006			8588	421
	200	HCG4008			11.451	471
	250	HCG40010			14.314	521
	300	HCG40012			17.177	571
500	50	HCG5002	522 (5114)	730,6	3653	344
	100	HCG5004			7306	394
	150	HCG5006			10.959	444
	200	HCG5008			14.612	494
	250	HCG50010			18.265	544
	300	HCG50012			21.918	594
600	50	HCG6002	611 (5987)	855,3	4276	352
	100	HCG6004			8553	402
	150	HCG6006			12.829	452
	200	HCG6008			17.106	502
	250	HCG60010			21.382	552
	300	HCG60012			25.659	602
800	50	HCG8002	831 (8149)	1164,2	5821	404
	100	HCG8004			11.642	454
	150	HCG8006			17.462	504
	200	HCG8008			23.283	554
	250	HCG80010			29.104	604
	300	HCG80012			34.925	654
1000	50	HCG10002	1085 (10.644)	1520,5	7603	442
	100	HCG10004			15.205	492
	150	HCG10006			22.808	542
	200	HCG10008			30.411	592
	250	HCG100010			38.013	642
	300	HCG100012			45.616	692

Single-Acting, High Tonnage Cylinders



▲ Offshore wind turbines levelling: Enerpac's synchronous lifting system was the solution for levelling support cross pieces on 80 wind turbines.

HCG Series



Capacity:
400 - 1000 ton

Stroke:
50 - 300 mm

Maximum Operating Pressure:
700 bar

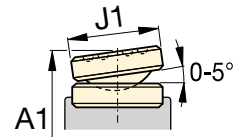

CATS-Series Tilt Saddle

Extended Height B (mm)	Outside Diameter D (mm)	Cylinder Bore Diameter E (mm)	Plunger Diameter F (mm)	Base to Advance Port H (mm)	Standard Saddle Diameter J (mm)	Saddle Protrusion from Plunger K (mm)	 (kg)	Model Number	Optional Tilt Saddle		
									Saddle Diameter J1 (mm)	Collapsed Height * A1 (mm)	Saddle Model Number
371	350	270	220	74	159	4	227	HCG4002	210	369	CATS400
471							257	HCG4004			
571							287	HCG4006			
671							317	HCG4008			
771							347	HCG40010			
871							378	HCG40012			
394	400	305	250	79	179	4	319	HCG5002	230	392	CATS500
494							359	HCG5004			
594							399	HCG5006			
694							439	HCG5008			
794							479	HCG50010			
894							519	HCG50012			
402	430	330	270	85	194	4	378	HCG6002	250	405	CATS600
502							424	HCG6004			
602							470	HCG6006			
702							516	HCG6008			
802							562	HCG60010			
902							608	HCG60012			
454	505	385	320	100	224	4	606	HCG8002	275	461	CATS800
554							671	HCG8004			
654							735	HCG8006			
754							800	HCG8008			
854							864	HCG80010			
954							929	HCG80012			
492	570	440	340	114	249	4	840	HCG10002	300	519	CATS1000
592							916	HCG10004			
692							992	HCG10006			
792							1068	HCG10008			
892							1145	HCG100010			
992							1221	HCG100012			

* A1 = Collapsed height including CATS-Series tilt saddle.

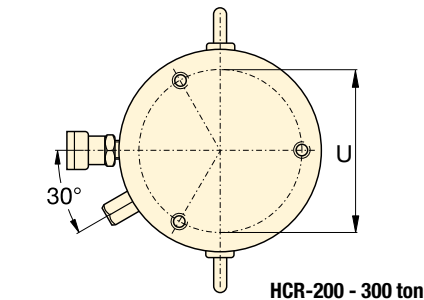
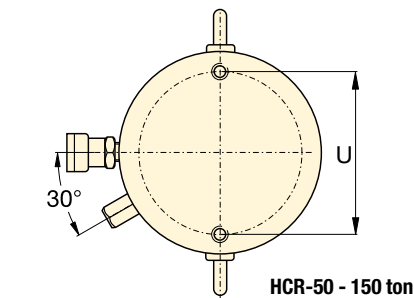
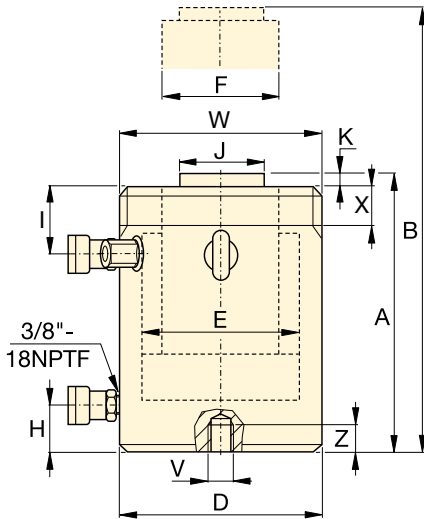

HCR-Series, Double-Acting Cylinders

- Fast advance and retract
- Designed to withstand 10% side-load of maximum capacity¹⁾
- Hardened surface resists side-loading and cyclic wear
- Weather protected, inside and out
- Upper and lower replaceable bearings enclose the cylinder plunger for support throughout the stroke
- Certified lifting eyes, base mounting holes and collar threads
- Standard collar thread up to 250 ton models. Collar thread is optional on 300 ton models and higher.

SELECTION CHART & DETAILS OF 50 - 300 TON HCR-MODELS

For 400 - 1000 ton models, see pages 54-55.

For full product features see pages 44-45.

Cylinder Capacity ton	Stroke (mm)	Model Number	Maximum Cylinder Capacity at 700 bar ton (kN)	Cylinder Effective Area (cm ²)	Oil Capacity (cm ³)		Collapsed Height A (mm)
					Advance	Retract	
50	50	HCR502	56 (550)	78,5	393	200	183
	100	HCR504			785	401	233
	150	HCR506 ¹⁾			1178	601	283
	200	HCR508			1571	801	346
	250	HCR5010			1963	1001	396
100	50	HCR1002	102 (1002)	143,1	716	361	202
	100	HCR1004			1431	723	252
	150	HCR1006			2147	1084	302
	200	HCR1008			2863	1445	379
	250	HCR10010			3578	1806	429
150	50	HCR1502	153 (1497)	213,8	1069	504	220
	100	HCR1504			2138	1007	270
	150	HCR1506			3207	1511	320
	200	HCR1508			4276	2015	397
	250	HCR15010			5346	2518	447
200	50	HCR2002	202 (1985)	283,5	1418	648	231
	100	HCR2004			2835	1296	281
	150	HCR2006			4253	1944	331
	200	HCR2008			5671	2592	408
	250	HCR20010			7088	3240	458
250	50	HCR2502	259 (2541)	363,1	1815	680	241
	100	HCR2504			3631	1361	291
	150	HCR2506			5446	2041	341
	200	HCR2508			7261	2721	431
	250	HCR25010			9076	3402	481
300	50	HCR3002	310 (3036)	433,7	2169	598	296
	100	HCR3004			4337	1196	346
	150	HCR3006			6506	1794	396
	200	HCR3008			8675	2392	446
	250	HCR30010			10.843	2989	496
300	300	HCR30012			13.012	3587	546

Collar Thread * (mm)		
Model / Capacity ton	Thread Size W	Thread Length X
HCR50	M130 x 2	30
HCR100	M175 x 3	46
HCR150	M215 x 3	55
HCR200	M250 x 3	63
HCR250	M280 x 3	64
HCR300*	M305 x 3	73

* Standard collar thread up to 250 ton models. Collar thread is optional on 300 ton models and higher. For collar thread on cylinder add suffix "E002" to model number. **Example: HCR3006E002**
The collar thread length is designed for the full rated cylinder capacity.

Base Mounting Holes (mm)					
Model / Capacity ton	Bolt Circle U	Thread Size V	Minimum Thread Depth Z	Number of Holes	Angle from Coupler
HCR50	105	M12 x 1,75	22	2	90°
HCR100	150	M12 x 1,75	22	2	90°
HCR150	185	M12 x 1,75	22	2	90°
HCR200	215	M12 x 1,75	22	3	60°
HCR250	245	M12 x 1,75	22	3	60°
HCR300	260	M16 x 2	25	3	60°

¹⁾ HCR506 and HCR5012: 7% side-load of maximum capacity.

Double-Acting, High Tonnage Cylinders

Capacity:
50 - 300 ton

Stroke:
50 - 300 mm

Maximum Operating Pressure:
700 bar

HCR Series

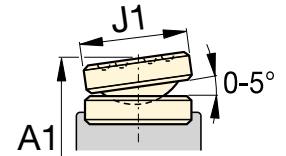

CATS-Series Tilt Saddle

	Extended Height B (mm)	Outside Diameter D (mm)	Cylinder Bore Diameter E (mm)	Plunger Diameter F (mm)	Base to Advance Port H (mm)	Top to Retract Port I (mm)	Standard Saddle Diameter J (mm)	Saddle Protrusion from Plunger K (mm)	 (kg)	Model Number
	233	130	100	70	38	45	50	3	17	HCR502
	333								21	HCR504
	433								25	HCR506 ¹⁾
	546								31	HCR508
	646								34	HCR5010
	746								38	HCR5012 ¹⁾
	252	175	135	95	38	65	75	3	34	HCR1002
	352								41	HCR1004
	452								48	HCR1006
	579								59	HCR1008
	679								66	HCR10010
	779								73	HCR10012
	270	215	165	120	41	70	94	3	56	HCR1502
	370								67	HCR1504
	470								78	HCR1506
	597								95	HCR1508
	697								106	HCR15010
	797								116	HCR15012
	281	250	190	140	47	79	113	3	81	HCR2002
	381								96	HCR2004
	481								111	HCR2006
	608								139	HCR2008
	708								153	HCR20010
	808								168	HCR20012
	291	280	215	170	53	79	140	4	107	HCR2502
	391								127	HCR2504
	491								146	HCR2506
	631								184	HCR2508
	731								207	HCR25010
	831								227	HCR25012
	346	305	235	200	58	101	140	4	159	HCR3002
	446								183	HCR3004
	546								208	HCR3006
	646								232	HCR3008
	746								257	HCR30010
	846								281	HCR30012

Optional Tilt Saddle		
Saddle Diameter J1 (mm)	Collapsed Height ²⁾ A1 (mm)	Saddle Model Number
71	197	CATS50
	247	
	297	
	360	
	410	
	460	
71	212	CATS101
	262	
	312	
	389	
	439	
	489	
97	239	CATS150
	289	
	339	
	416	
	466	
	516	
126	249	CATS200
	299	
	349	
	426	
	476	
	526	
175	280	CATS300
	330	
	380	
	470	
	520	
	570	
175	335	CATS300
	385	
	435	
	485	
	535	
	585	

²⁾ A1 = Collapsed height including CATS-Series tilt saddle.

HCR-Series, Double-Acting Cylinders

- Fast advance and retract
- Designed to withstand 10% side-load of maximum capacity
- Hardened surface resists side-loading and cyclic wear
- Weather protected, inside and out
- Upper and lower replaceable bearings enclose the cylinder plunger for support throughout the stroke
- Certified lifting eyes, base mounting holes and optional collar threads
- Optional collar threads on 300 ton models and higher capacities.

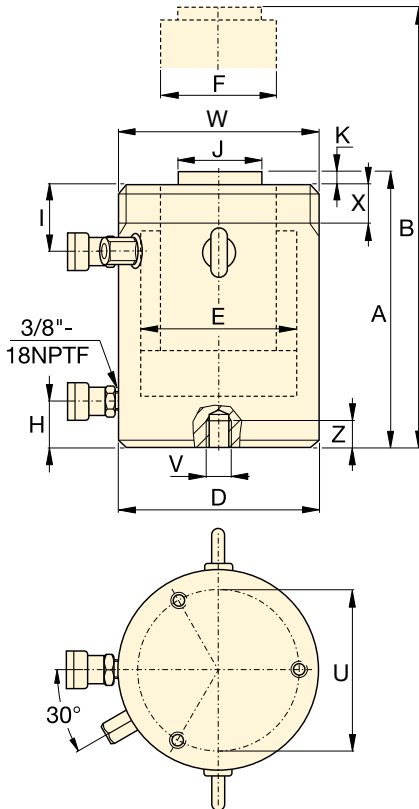

SELECTION CHART & DETAILS OF 400 - 1000 TON HCR-MODELS

For 50 - 300 ton models, see pages 52-53.

For full product features see pages 44-45.

Cylinder Capacity ton	Stroke (mm)	Model Number	Maximum Cylinder Capacity at 700 bar ton (kN)	Cylinder Effective Area (cm ²)	Oil Capacity (cm ³)		Collapsed Height A (mm)
					Advance	Retract	
400	50	HCR4002	409 (4008)	572,6	2863	962	321
	100	HCR4004			5726	1924	371
	150	HCR4006			8588	2886	421
	200	HCR4008			11.451	3848	471
	250	HCR40010			14.314	4811	521
	300	HCR40012			17.177	5773	571
500	50	HCR5002	522 (5114)	730,6	3653	1199	344
	100	HCR5004			7306	2397	394
	150	HCR5006			10.959	3596	444
	200	HCR5008			14.612	4795	494
	250	HCR50010			18.265	5994	544
	300	HCR50012			21.918	7192	594
600	50	HCR6002	611 (5987)	855,3	4276	1414	352
	100	HCR6004			8553	2827	402
	150	HCR6006			12.829	4241	452
	200	HCR6008			17.106	5655	502
	250	HCR60010			21.382	7069	552
	300	HCR60012			25.659	8482	602
800	50	HCR8002	831 (8149)	1164,2	5821	1800	404
	100	HCR8004			11.642	3599	454
	150	HCR8006			17.462	5399	504
	200	HCR8008			23.283	7198	554
	250	HCR80010			29.104	8998	604
	300	HCR80012			34.925	10.797	654
1000	50	HCR10002	1085 (10.644)	1520,5	7603	3063	442
	100	HCR10004			15.205	6126	492
	150	HCR10006			22.808	9189	542
	200	HCR10008			30.411	12.252	592
	250	HCR100010			38.013	15.315	642
	300	HCR100012			45.616	18.378	692

Optional Collar Thread (mm)

Model / Capacity ton	Thread Size	Thread Length
	W	X
HCR400	M350 x 3	83
HCR500	M400 x 4	90
HCR600	M430 x 4	100
HCR800	M505 x 5	122
HCR1000	M570 x 5	137

Collar thread is optional on 300 ton models and higher. For collar thread on cylinder add suffix "E002" to model number. Example: **HCR4006E002**

The collar thread length is designed for the full rated cylinder capacity.

Base Mounting Holes (mm)

Model / Capacity ton	Bolt Circle	Thread Size	Minimum Thread Depth	Number of Holes	Angle from Coupler
	U	V	Z		
HCR400	300	M16 x 2	25	3	60°
HCR500	340	M24 x 3	36	3	60°
HCR600	370	M24 x 3	36	3	60°
HCR800	440	M24 x 3	36	3	60°
HCR1000	500	M24 x 3	36	3	60°

Double-Acting, High Tonnage Cylinders



▲ The superlifting and launch of a 43,000-ton floating oil production system in Malaysia for the Gumusut-Kakap offshore field has set high benchmarks for safety through its use of sophisticated EVO-Series synchronous hydraulics to lift, balance, weigh and smoothly launch massive resource structures.

HCR Series



Capacity:
400 - 1000 ton

Stroke:
50 - 300 mm

Maximum Operating Pressure:
700 bar

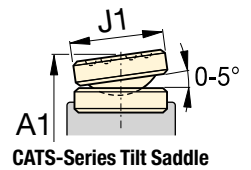

CATS-Series Tilt Saddle

Extended Height B (mm)	Outside Diameter D (mm)	Cylinder Bore Diameter E (mm)	Plunger Diameter F (mm)	Base to Advance Port H (mm)	Top to Retract Port I (mm)	Standard Saddle Diameter J (mm)	Saddle Protrusion from Plunger K (mm)	Model Number	Optional Tilt Saddle			
									Saddle Diameter J1 (mm)	Collapsed Height * A1 (mm)	Saddle Model Number	
371	350	270	220	74	111	159	4	227	210	369	CATS400	
471								258				419
571								289				469
671								321				519
771								352				569
871								383				619
394	400	305	250	79	121	179	4	320	230	392	CATS500	
494								361				442
594								402				492
694								443				542
794								484				592
894								525				642
402	430	330	270	85	121	194	4	379	250	405	CATS600	
502								427				455
602								474				505
702								521				555
802								568				605
902								615				655
454	505	385	320	100	143	224	4	608	275	461	CATS800	
554								674				511
654								740				561
754								806				611
854								872				661
954								938				711
492	570	440	340	114	153	249	4	843	300	519	CATS1000	
592								921				569
692								1000				619
792								1079				669
892								1158				719
992								1236				769

* A1 = Collapsed height including CATS-Series tilt saddle.

HCL-Series, Single-Acting, Gravity Return Cylinders

- Lock nut provides positive and safe mechanical load holding
- Low-friction locking rings spin easy, save time and effort
- Designed to withstand 10% side-load up to 90% of maximum stroke
- Hardened surface resists side-loading and cyclic wear
- Overflow port as stroke limiter to prevent plunger blow-out
- Weather protected, inside and out
- Replaceable bearings enclose the plunger for support throughout the stroke
- Certified lifting eyes and base mounting holes.

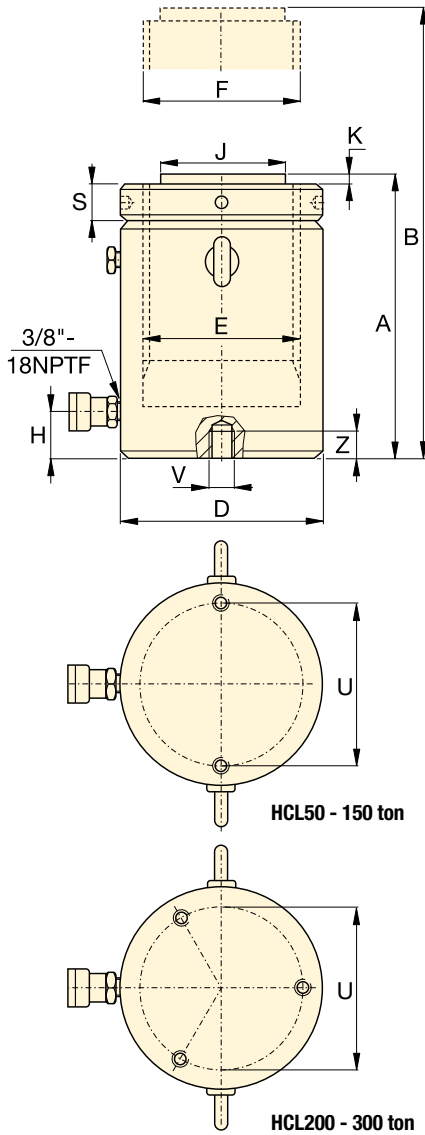

SELECTION CHART 50 - 300 TON HCL-MODELS

For 400 - 1000 ton models, see pages 58-59.

For full product features see pages 44-45.

Cylinder Capacity ton	Stroke (mm)	Model Number	Maximum Cylinder Capacity at 700 bar ton (kN)	Cylinder Effective Area (cm ²)	Oil Capacity (cm ³)	Collapsed Height A (mm)
50	50	HCL502	56 (550)	78,5	393	164
	100	HCL504			785	214
	150	HCL506			1178	264
	200	HCL508			1571	314
	250	HCL5010			1963	364
	300	HCL5012			2356	414
100	50	HCL1002	102 (1002)	143,1	716	187
	100	HCL1004			1431	237
	150	HCL1006			2147	287
	200	HCL1008			2863	337
	250	HCL10010			3578	387
	300	HCL10012			4294	437
150	50	HCL1502	153 (1497)	213,8	1069	209
	100	HCL1504			2138	259
	150	HCL1506			3207	309
	200	HCL1508			4276	359
	250	HCL15010			5346	409
	300	HCL15012			6415	459
200	50	HCL2002	202 (1985)	283,5	1418	238
	100	HCL2004			2835	288
	150	HCL2006			4253	338
	200	HCL2008			5671	388
	250	HCL20010			7088	438
	300	HCL20012			8506	488
250	50	HCL2502	259 (2541)	363,1	1815	249
	100	HCL2504			3631	299
	150	HCL2506			5446	349
	200	HCL2508			7261	399
	250	HCL25010			9076	449
	300	HCL25012			10.892	499
300	50	HCL3002	310 (3036)	433,7	2169	278
	100	HCL3004			4337	328
	150	HCL3006			6506	378
	200	HCL3008			8675	428
	250	HCL30010			10.843	478
	300	HCL30012			13.012	528

Base Mounting Holes (mm)					
Model / Capacity ton	Bolt Circle U	Thread Size V	Minimum Thread Depth Z	Number of Holes	Angle from Coupler
HCL50	105	M8 x 1,25	10	2	90°
HCL100	150	M12 x 1,75	17	2	90°
HCL150	185	M12 x 1,75	22	2	90°
HCL200	215	M12 x 1,75	22	3	60°
HCL250	245	M12 x 1,75	22	3	60°
HCL300	260	M16 x 2	25	3	60°

Single-Acting, Lock Nut Cylinders

Capacity:
50 - 300 ton

Stroke:
50 - 300 mm

Maximum Operating Pressure:
700 bar

HCL Series

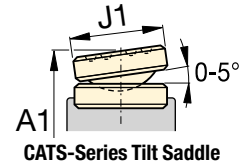

Extended Height	Outside Diameter	Cylinder Bore Diameter	Plunger Diameter (threaded)	Base to Advance Port	Standard Saddle Diameter	Saddle Protrusion from Plunger	Lock Nut Height	Model Number	Optional Tilt Saddle				
									Saddle Diameter J1 (mm)	Collapsed Height * A1 (mm)	Saddle Model Number		
214	130	100	Tr 100 x 4	24	71	2	25	17	HCL502	71	179	CATS100	
314								22					229
414								27					279
514								32					329
614								38					379
714								43					429
237	175	135	Tr 135 x 6	33	71	2	33	35	HCL1002	71	202	CATS100	
337								44					252
437								54					302
537								63					352
637								73					402
737								82					452
259	215	165	Tr 165 x 6	41	130	2	40	59	HCL1502	126	225	CATS201	
359								73					275
459								87					325
559								102					375
659								116					425
759								130					475
288	250	190	Tr 190 x 6	47	130	2	45	85	HCL2002	126	254	CATS201	
388								105					304
488								124					354
588								143					404
688								163					454
788								182					504
299	280	215	Tr 215 x 6	53	140	2	52	119	HCL2502	175	288	CATS300	
399								143					338
499								167					388
599								192					438
699								216					488
799								240					538
328	305	235	Tr 235 x 6	58	140	2	56	158	HCL3002	175	317	CATS300	
428								186					367
528								215					417
628								244					467
728								272					517
828								301					567

* A1 = Collapsed height including CATS-Series tilt saddle.

HCL-Series, Single-Acting, Gravity Return Cylinders

- Lock nut provides positive and safe mechanical load holding
- Low-friction locking rings spin easy, save time and effort
- Designed to withstand 10% side-load up to 90% of maximum stroke
- Hardened surface resists side-loading and cyclic wear
- Overflow port as stroke limiter to prevent plunger blow-out
- Weather protected, inside and out
- Replaceable bearings enclose the plunger for support throughout the stroke
- Certified lifting eyes and base mounting holes.

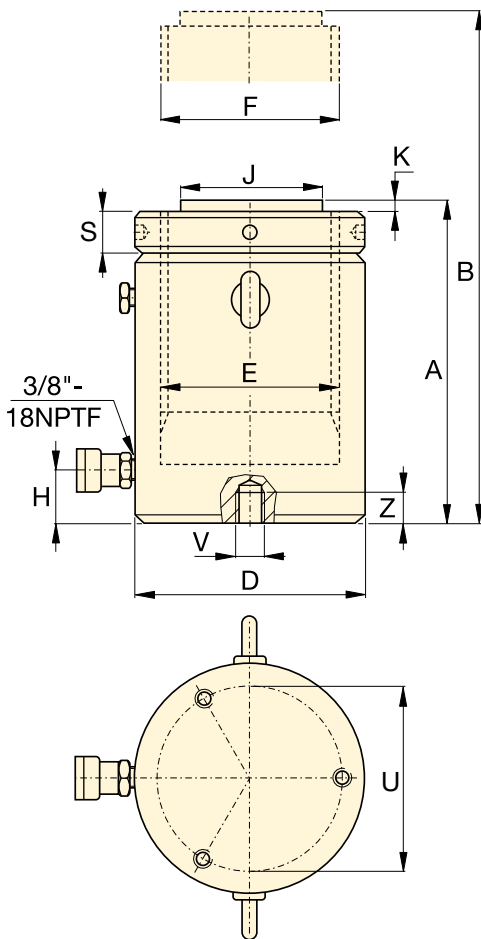

SELECTION CHART 400 - 1000 TON HCL-MODELS

For 50 - 300 ton models, see pages 56-57.

For full product features see pages 44-45.

Cylinder Capacity	Stroke	Model Number	Maximum Cylinder Capacity at 700 bar ton (kN)	Cylinder Effective Area	Oil Capacity	Collapsed Height
ton	(mm)		ton (kN)	(cm ²)	(cm ³)	A (mm)
400	50	HCL4002	409 (4008)	572,6	2863	317
	100	HCL4004			5726	367
	150	HCL4006			8588	417
	200	HCL4008			11.451	467
	250	HCL40010			14.314	517
	300	HCL40012			17.177	567
500	50	HCL5002	522 (5114)	730,6	3653	357
	100	HCL5004			7306	407
	150	HCL5006			10.959	457
	200	HCL5008			14.612	507
	250	HCL50010			18.265	557
	300	HCL50012			21.918	607
600	50	HCL6002	611 (5987)	855,3	4276	380
	100	HCL6004			8553	430
	150	HCL6006			12.829	480
	200	HCL6008			17.106	530
	250	HCL60010			21.382	580
	300	HCL60012			25.659	630
800	50	HCL8002	831 (8149)	1164,2	5821	430
	100	HCL8004			11.642	480
	150	HCL8006			17.462	530
	200	HCL8008			23.283	580
	250	HCL80010			29.104	630
	300	HCL80012			34.925	680
1000	50	HCL10002	1085 (10.644)	1520,5	7603	484
	100	HCL10004			15.205	534
	150	HCL10006			22.808	584
	200	HCL10008			30.411	634
	250	HCL100010			38.013	684
	300	HCL100012			45.616	734

Base Mounting Holes (mm)					
Model / Capacity ton	Bolt Circle U	Thread Size V	Minimum Thread Depth Z	Number of Holes	Angle from Coupler
HCL400	300	M16 x 2	25	3	60°
HCL500	340	M24 x 3	36	3	60°
HCL600	370	M24 x 3	36	3	60°
HCL800	440	M24 x 3	36	3	60°
HCL1000	500	M24 x 3	36	3	60°

Single-Acting, Lock Nut Cylinders



▲ Heavy lifting and foundation levelling. The lock nut provides mechanical load holding over a long period of time.

HCL Series



Capacity:
400 - 1000 ton

Stroke:
50 - 300 mm

Maximum Operating Pressure:
700 bar

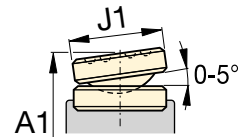

CATS-Series Tilt Saddle

Extended Height B (mm)	Outside Diameter D (mm)	Cylinder Bore Diameter E (mm)	Plunger Diameter (threaded) F (mm)	Base to Advance Port H (mm)	Standard Saddle Diameter J (mm)	Saddle Protrusion from Plunger K (mm)	Lock Nut Height S (mm)	🏋️ (kg)	Model Number	Optional Tilt Saddle			
										Saddle Diameter J1 (mm)	Collapsed Height * A1 (mm)	Model Number	
367	350	270	Tr 270 x 6	67	159	5	65	236	HCL4002	210	365	CATS400	
467								274	HCL4004				415
567								311	HCL4006				465
667								349	HCL4008				515
767								387	HCL40010				565
867								425	HCL40012				615
407								400	305				Tr 305 x 6
507	390	HCL5004	455										
607	439	HCL5006	505										
707	489	HCL5008	555										
807	538	HCL50010	605										
907	587	HCL50012	655										
430	430	330	Tr 330 x 6	81	194	5	80			427	HCL6002	250	
530								484	HCL6004	483			
630								541	HCL6006	533			
730								598	HCL6008	583			
830								655	HCL60010	633			
930								712	HCL60012	683			
480								505	385	Tr 385 x 6	95		224
580	746	HCL8004	537										
680	825	HCL8006	587										
780	904	HCL8008	637										
880	982	HCL80010	687										
980	1061	HCL80012	737										
534	570	440	Tr 440 x 6	110	249	5	105					959	
634								1059	HCL10004	611			
734								1160	HCL10006	661			
834								1260	HCL10008	711			
934								1360	HCL100010	761			
1034								1460	HCL100012	811			

* A1 = Collapsed height including CATS-Series tilt saddle.

HCRL-Series, Double-Acting Lock Nut Cylinders



▼ HCRL-2006, HCRL-506



- Hydraulically controlled fast retraction
- Lock nut provides mechanical load holding for a safe work environment
- Designed to withstand up to 10% side-load of maximum capacity
- Integrated tilt saddle allows up to 5 degrees of misalignment
- Hardened surface resists side-loading and cyclic wear
- Weather protected, inside and out
- Replaceable bearings enclose the plunger external and internally for support
- Certified lifting eyes, base mounting holes and collar thread as standard
- Stop-ring to prevent plunger blow-out
- Low friction lock nut, to spin easily, save time and effort.

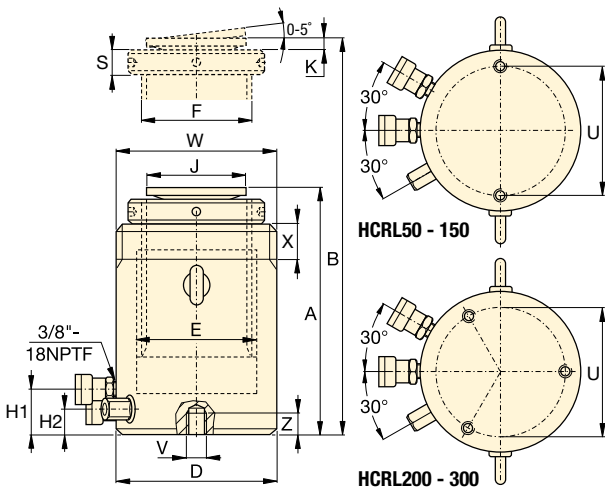

SELECTION CHART 50 - 300 TON HCRL-MODELS

For full product features see pages 44-45.

Cylinder Capacity * ton	Stroke * (mm)	Model Number	Maximum Cylinder Capacity at 700 bar ton (kN)	Cylinder Effective Area (cm ²)	Oil Capacity (cm ³)	
					Advance	Retract
50	150	HCRL506	49 (479)	68,4	1025	86
	200	HCRL508			1367	115
	250	HCRL5010			1709	143
	300	HCRL5012			2051	172
100	150	HCRL1006	101 (990)	141,4	2121	236
	200	HCRL1008			2827	314
	250	HCRL10010			3534	393
	300	HCRL10012			4241	471
150	150	HCRL1506	153 (1501)	214,4	3216	236
	200	HCRL1508			4288	314
	250	HCRL15010			5360	393
	300	HCRL15012			6432	471
200	150	HCRL2006	204 (2001)	285,9	4288	530
	200	HCRL2008			5718	707
	250	HCRL20010			7147	884
	300	HCRL20012			8577	1060
250	150	HCRL2506	251 (2463)	351,9	5278	530
	200	HCRL2508			7037	707
	250	HCRL25010			8796	884
	300	HCRL25012			10.556	1060
300	150	HCRL3006	303 (2969)	424,1	6362	530
	200	HCRL3008			8482	707
	250	HCRL30010			10.603	884
	300	HCRL30012			12.723	1060

* Up to 2000 ton and additional stroke lengths available on request.

Collar Thread (mm)		
Model / Capacity ton	Thread Size W	Thread Length X
HCRL50	M130 x 2	42
HCRL100	M185 x 2	57
HCRL150	M222 x 3	70
HCRL200	M260 x 3	79
HCRL250	M290 x 3	85
HCRL300	M315 x 3	94

The collar thread length is designed for the full rated cylinder capacity.

Base Mounting Holes (mm)			
Model / Capacity ton	Bolt Circle U	Thread Size V	Minimum Thread Depth Z
HCRL50	105	M12 x 1,75	22
HCRL100	150	M12 x 1,75	22
HCRL150	185	M12 x 1,75	22
HCRL200	215	M12 x 1,75	22
HCRL250	245	M12 x 1,75	22
HCRL300	260	M16 x 2	25

Double-Acting Lock Nut Cylinders



Higher Capacities, Larger Strokes

The HCRL-Series Cylinders are available up to 2000 ton capacity and additional stroke lengths available on request.

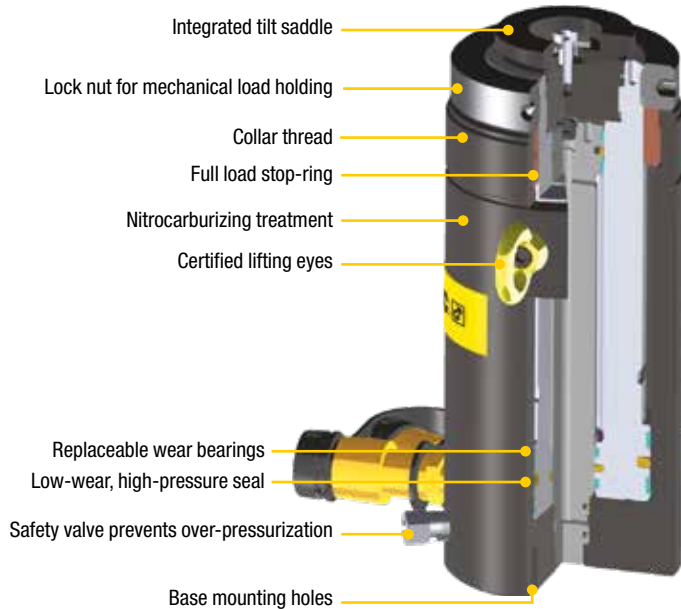

HCRL Series

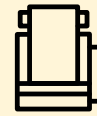

Capacity:

50 - 300 ton

Stroke:

150 - 300 mm

Maximum Operating Pressure:

700 bar



Synchronous Lifting Systems

EVO-Series pumps the multi-functional lifting system and multiple lift point capabilities.

Page: **350**

Collapsed Height A (mm)	Extended Height B (mm)	Outside Diameter D (mm)	Cylinder Bore Diameter E (mm)	Plunger Diameter (threaded) F (mm)	Base to Advance Port H1 (mm)	Base to Retract Port H2 (mm)	Saddle Diameter J (mm)	Saddle Protrusion K (mm)	Lock Nut Height S (mm)	(kg)	Model Number
310	460	130	100	Tr 90 x 4	41	27	77	15	26	30	HCRL506
377	577									36	HCRL508
427	677									40	HCRL5010
477	777									45	HCRL5012
346	496	185	140	Tr 120 x 6	50	36	77	15	36	64	HCRL1006
421	621									77	HCRL1008
471	721									85	HCRL10010
521	821									94	HCRL10012
359	509	222	170	Tr 150 x 6	46	32	126	13	45	97	HCRL1506
434	634									116	HCRL1508
484	734									129	HCRL15010
534	834									142	HCRL15012
399	549	260	200	Tr 170 x 6	71	49	126	13	50	145	HCRL2006
469	669									168	HCRL2008
519	769									184	HCRL20010
569	869									200	HCRL20012
416	566	290	220	Tr 190 x 6	71	49	160	15	55	190	HCRL2506
491	691									224	HCRL2508
541	791									244	HCRL25010
591	891									265	HCRL25012
421	571	315	240	Tr 210 x 6	71	49	160	15	55	230	HCRL3006
496	696									269	HCRL3008
546	796									294	HCRL30010
596	896									319	HCRL30012

▼ SCR1010H cylinder-pump set



The Quickest and Easiest Way to Start Working Right Away



Speed Chart

See the Enerpac Cylinder Speed Chart in our 'Yellow Pages' section.

Page: 415

- Optimum match of individual components
- All sets are ready-for-use
- Sets include 1,8 m safety hose and gauge with gauge adaptor
- All pumps are two-speed.

1 Cylinder Selection (See Cylinder Section of this catalog for full product descriptions)		Set Capacity ton (kN)	Cylinder Model Number	Stroke (mm)	Collapsed Height (mm)
<p>RC-Series, Single-Acting, General Purpose Cylinders For maximum versatility.</p>	<p>Page: 6</p>	5 (45)	RC55	127	216
		10 (101)	RC102	54	121
			RC106	156	248
			RC1010	257	349
		15 (142)	RC154	101	200
			RC156	152	271
		25 (232)	RC252	50	165
			RC254	102	216
			RC256	158	273
			RC2514	362	476
50 (498)	RC506	159	282		
<p>RCS-Series, Single-Acting, Low-Height Cylinders Ideal where space is restricted.</p>	<p>Page: 26</p>	10 (101)	RCS101	38	88
		20 (201)	RCS201	45	98
		30 (295)	RCS302	62	117
		45 (435)	RCS502	60	122
		90 (887)	RCS1002	57	141
<p>RCH-Series, Single-Acting, Hollow Cylinders For pushing and pulling applications.</p>	<p>Page: 34</p>	13 (125)	RCH121	42	120
		20 (215)	RCH202	49	162
		30 (326)	RCH302	64	178
		60 (576)	RCH603	76	247
		95 (933)	RCH1003	76	254

Single-Acting Cylinder-Pump Sets

SET SELECTION:

- 1 Select the cylinder
- 2 Select the pump
- 3 Find the set model number in the gray matrix

SELECTION EXAMPLE

Selected cylinder:

- RC106, Single-Acting cylinder with 156 mm stroke

Selected pump:

- P392, Lightweight hand pump

Set model number:

- SCR106H

Included:

- HC7206 hose
- GF10B gauge
- GA2 adaptor



GA45GC Gauge Adaptor Assembly

Protect yourself from system overloading by simply ordering one partnumber for a pre-assembled gauge, gauge adaptor and coupler.

Page: 142

SC Series



Capacity:

5 - 95 ton

Stroke:

38 - 362 mm

Maximum Operating Pressure:

700 bar



Power Box

Tool box with hand pump, gauge adaptor assembly, hose and LW-, RC-, RCS, RSM- or WR-Series cylinder.

Page: 65

2

Pump selection (See the Pump Section in this catalog for full product descriptions.)

Accessories included

3

Hand Pump P142	Hand Pump P392	Hand Pump P80	Foot Pump P392FP	XA-Series Air Pump XA11	XC-Series Cordless Pump XC1201ME ²⁾	Hose Model Number	Gauge Model Number	Gauge Adaptor Model Nr.
SCR55H	-	-	-	-	-	HC7206	GP10S	GA4
-	SCR102H	-	SCR102FP	SCR102XA	SCR102XCE	HC7206	GF10B	GA2
-	SCR106H	-	SCR106FP	SCR106XA	SCR106XCE	HC7206	GF10B	GA2
-	SCR1010H	-	SCR1010FP	SCR1010XA	SCR1010XCE	HC7206	GF10B	GA2
-	SCR154H	-	SCR154FP	SCR154XA	SCR154XCE	HC7206	GP10S	GA2
-	SCR156H	-	SCR156FP	SCR156XA	SCR156XCE	HC7206	GP10S	GA2
-	SCR252H	-	SCR252FP	SCR252XA	SCR252XCE	HC7206	GF20B	GA2
-	SCR254H	-	SCR254FP	SCR254XA	SCR254XCE	HC7206	GF20B	GA2
-	SCR256H	-	-	SCR256XA	SCR256XCE	HC7206	GF20B	GA2
-	-	SCR2514H	-	SCR2514XA ¹⁾	-	HC7206	GF20B	GA2
-	-	SCR506H	-	SCR506XA ¹⁾	-	HC7206	GF50B	GA2
-	SCL101H	-	SCL101FP	SCL101XA	-	HC7206	GF10B	GA2
-	SCL201H	-	SCL201FP	SCL201XA	-	HC7206	GF230B	GA2
-	SCL302H	-	SCL302FP	SCL302XA	SCL302XCE	HC7206	GF230B	GA2
-	SCL502H	-	SCL502FP	SCL502XA	SCL502XCE	HC7206	GF510B	GA2
-	-	SCL1002H	-	-	SCL1002XCE	HC7206	GF510B	GA2
SCH121H	-	-	-	-	-	HB7206	GF120B	GA4
-	SCH202H	-	SCH202FP	SCH202XA	SCH202XCE	HC7206	GF813B	GA3
-	SCH302H	-	SCH302FP	SCH302XA	SCH302XCE	HC7206	GF813B	GA3
-	-	SCH603H	-	SCH603XA ¹⁾	SCH603XCE	HC7206	GF813B	GA3
-	-	SCH1003H	-	-	-	HC7206	GP10S	GA2

¹⁾ With XA12 air pump.

²⁾ Cordless Pump includes 230V Charger. For 115V charger replace the "E" by the "B" in the model number.

▼ From left to right: P142ALSS, P392ALSS, V152NV, V66NV, RC256NV, RC106NV, RC53NV



- Corrosion resistant, nickel-plated valves and cylinders
- Stainless steel pump inserts will not corrode
- Viton® Seals provide heat and chemical resistance
- Anodized aluminum pump reservoirs and plastic encapsulated pump bodies resist wet environments
- Two-speed operation reduces pump handle strokes 78% compared to single-speed pumps
- Pump handles lock for easy carrying.

RC, P, V Series

Cylinder Capacity:
5 - 25 ton

Stroke:
51 - 156 mm

Maximum Operating Pressure:
700 bar



Applications



For use in wet environments such as food processing, pulp and paper, mining, construction and applications in high temperature or in welding areas.







Multifluid Hand Pumps

MP-Series corrosion resistant hand pumps for low pressure filling and high pressure testing applications, suitable for a wide range of fluids.

Page: **82**

	Cylinder Capacity	Stroke	Model Number *	Oil Capacity	Pressure Rating	Collapsed Height	Extended Height	Outside Diameter	
	ton (kN)	(mm)		(cm ³)	(bar)	(mm)	(mm)	(mm)	(kg)
	5 (45)	76	RC53NV	50	700	165	241	38	1,5
	10 (101)	51	RC102NV	78	700	121	175	57	2,3
	10 (101)	156	RC106NV	225	700	247	403	57	4,4
	25 (232)	156	RC256NV	528	700	273	431	85	10,0

	Pump Type	Oil Capacity	Model Number *	Pressure Rating	Oil Displacement per Stroke	Port Dimension	Piston Stroke	
		(cm ³)		(bar)	(cm ³)	(NPTF)	(mm)	(kg)
	Two Speed	327	P142ALSS	14 / 700	3,62 / 0,90	1/4"-18	12,7	2,0
		901	P392ALSS	14 / 700	11,26 / 2,47	3/8"-18	25,4	4,1

	Valve Type	Model Number *	Function	Pressure Rating (bar)	
	Manual Check Valve	V66NV *	Load holding with cylinders	700	1,8
	Pressure Relief Valve	V152NV *	Limits system pressure, ± 3% repeatability	55-700	1,6

* For cylinder details see pages 7-9; for pump details see pages 76-77; for valve details see pages 144-145.

Power Box – Portable Tool Sets

▼ SCR154PGH



- Easy to carry sturdy tool box
- Complete and ready-to-use hydraulic sets
- Includes a single-acting cylinder, P392 two-speed lightweight hand pump, gauge adaptor assembly, 1,8 metres hose and couplers
- All components ship inside tool box as one package.

**SC,
SL,
SR,
SW
Series**



Capacity:

1 - 45 ton

Stroke:

11 - 156 mm

Maximum Operating Pressure:







700 bar



Gauge Adaptor Assembly

Power Box Sets include 45 degree angled gauge adaptor assembly for improved safe working conditions.

Page: 127

	Cylinder Model	Cylinder Stroke (mm)	Cylinder Capacity ton (kN)	 (kg)	Power Box Model Number
	Lifting Wedge				
	LW16	21	16 (157)	9,0	SLW16PGH ²⁾
	Wedge Spread Cylinder				
	WR5	94 ¹⁾	1,0 (8,9)	12,0	SWR5PGH
	General Purpose Cylinders				
	RC102	54	10 (101)	12,3	SCR102PGH
	RC106	156	10 (101)	14,4	SCR106PGH
	RC154	101	15 (142)	15,0	SCR154PGH
	RC156	152	15 (142)	16,8	SCR156PGH
	Low-Height Cylinders				
	RCS101	38	10 (101)	14,1	SCL101PGH
	RCS201	45	20 (201)	15,0	SCL201PGH
	Low-Height Cylinders				
	RSM100	11	10 (101)	11,4	SRS100PGH
	RSM200	11	20 (201)	13,1	SRS200PGH
	RSM300	13	30 (295)	14,5	SRS300PGH
	RSM500	16	45 (435)	16,8	SRS500PGH

¹⁾ Maximum spread of WR5.

²⁾ With P142 two-speed lightweight hand pump.

▼ The Power Box – the portable tool set – applicable everywhere.



▼ Shown from left to right: JHA356, JHA156



JH, JHA Series

Capacity:
7 - 100 ton

Stroke:
76 - 155 mm

Maximum Operating Pressure:
700 bar

- All-directional operation on 7, 15 and 35 ton JHA-series
- Internal relief valve to prevent overloading
- Machined flat front and bottom surfaces permit flush alignment in tight corners
- Chrome plated plungers
- Pumping handle included
- Automatic by-pass port to prevent over-extension (JH-series).



Lifting Wedge and Machine Lifts

Ideal to lift the load the first few centimeters. The LW16 Lifting Wedge requires a very small access gap of only 10 mm.

Page: **188**



Load Skates

For moving heavy loads easily and safely.

Page: **192**

Style	Jack Capacity ton (kN)	Stroke (mm)	Model Number	Jack Effective Area (cm ²)	Collapsed Height (mm)	Extended Height (mm)	Bottom Plate Dimensions W x L (mm)	Plunger Diameter (mm)	Pump Speed	 (kg)
Aluminium Jacks	7 (62)	76	JHA73	9,6	133	209	73 x 158	30,2	Single	5,0
	15 (133)	153	JHA156	20,3	247	401	92 x 238	41,4	Single	13,2
	35 (311)	155	JHA356	45,6	257	412	117 x 254	54,1	Single	18,1
Steel Jacks	30 (267)	155	JH306	38,3	254	409	95 x 242	69,9	Single	26,8
	50 (445)	154	JH506	62,1	260	414	127 x 258	88,9	2-Speed	40,8
	100 (890)	153	JH1006	133,1	287	440	181 x 328	130,1	2-Speed	74,4

Industrial Steel Bottle Jacks

▼ Shown: GBJ010A, GBJ030A, GBJ003A



- Lower handle effort reduces operator fatigue
- Fully serviceable
- High-strength beam and pump linkage for long life
- Pumping handle included on all models
- Safety relief valve to prevent overload
- Automatic by-pass port to prevent over-extension
- Wiper seal for extended life
- Thick base material with large area for increased strength and stability during lifting
- Positioning handle on 20 ton through 50 ton models.

GBJ Series



Capacity:

2 - 100 ton

Stroke:

62 - 460 mm



Screw Extension Feature

Heat treated, adjustable extension screw with cleated saddle on selected GBJ models helps adjusting and prevents slipping.

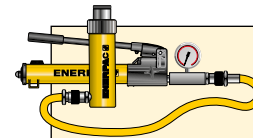

Cylinder-Pump Sets

As an alternative to bottle jacks where the operator is required to stand remote from the jacking point, see our range of cylinder-pump sets.

Page: **62**

Capacity ton (kN)	Stroke (mm)	Model Number	Screw Extension (mm)	Min. Height (mm)	Max. Height (mm)	Plunger diameter (mm)	Saddle Diameter (mm)	Bottom Dimensions W x L (mm)	 (kg)
2 (19,6)	460	GBJ002LA	-	570	1030	29	-	75 x 116	10,3
3 (29,4)	105	GBJ003A	65	168	338	24	23,5	75 x 116	3,7
5 (49,0)	150	GBJ005A	75	212	437	29	28,5	75 x 125	4,5
8 (78,4)	150	GBJ008A	75	219	444	37	38,0	90 x 144	6,2
10 (98,0)	150	GBJ010A	75	219	444	37	38,0	90 x 144	6,4
10 (98,0)	62	GBJ010SA	30	131	223	37	38,0	90 x 144	5,0
15 (147,0)	150	GBJ015A	75	228	453	45	45,0	112 x 163	8,8
20 (196,0)	150	GBJ020A	75	234	459	51	61,0	120 x 172	10,6
20 (196,0)	105	GBJ020SA	55	190	350	51	61,0	120 x 172	9,5
30 (294,0)	150	GBJ030A	75	242	467	58	69,0	144 x 196	15,5
50 (490,0)	140	GBJ050A	-	260	400	80	80,0	165 x 214	27,0
100 (980,0)	150	GBJ100	-	300	450	110	94,0	296 x 333	87,0

All GBJ Jacks meet or exceed: ANSI, PALD, CE.

▼ Enerpac heavy-duty bottle jacks make lifting loads easier.



▼ Shown: PRASA10027L and accessory Locking U-Rings



Safe, Efficient, Mobile Load Lifting



Pendant cord

Supplied with 3,5 m pendant cord for air driven units with pneumatic valves and 6 m pendant cord for electric driven units keeps operator away from the load.

- 54, 90, 136 and 181 ton capacities with pneumatic or electric pumps for the toughest jobs
- 102 mm ground clearance for transport over rail and rough terrain
- Double-acting cylinder
- Three position handle provides easy tilt back and transport
- Complies with ASME/ANSI B30:1 2015 and CE specifications
- Easy to change external filter minimizes down time
- Rugged, fully enclosed 610 mm wide frame with no exposed fittings or hoses
- SUP-R-STACK™ Extension System allows lifting at all heights without blocking.



POW'R-LOCK™ – Self-Locking Mobile Lift System

A self-locking jack that performs automatic locking during lifting, lowering and holding.

See the Enerpac PL-Series

Page: 70



◀ Enerpac POW'R-RISER® used in mining operations to lift heavy equipment.

Capacity ton (kN)	Stroke (mm)	Model Number with Electric Pump (230V - 1 ph - 50Hz)	 (kg)
54 (533)	356	PREME06014L	177
	686	PREME06027L	272
90 (889)	406	PREME10016L	231
	686	PREME10027L	272
	406	-	-
	686	-	-
136 (1333)	394	-	-
	673	-	-
	394	PREME15016L	258
	673	PREME15027L	321
181 (1778)	388	-	-
	617	-	-

POW'R-RISER® Lifting Jack



SUP-R-STACK Extensions

Increase useful height from 127 to 457 mm.

Model No.	Size (mm)	Model No.	Size (mm)
PRE5	127	PRE11	279
PRE7	178	PRE14	356
PRE9	229	PRE18	457
PRES6024	Extension set includes PRE5, PRE7, PRE11 and PRE18.		



Spacers

Fine tune your extension stack height.

Model No.	Size (mm)	Model No.	Size (mm)
PRS1	25	PRS3	76
PRS2	51	-	-
PRS4	Set includes (2x) PRS1, (1x) PRS2 and (1x) PRS3.		

PR Series



Rated Lifting Capacity:

54 - 181 ton

Stroke:

356 - 686 mm

Maximum Operating Pressure:

700 bar

Cap. (kN)	Swivel Load Saddle	Locking U-Rings					Set Model Number	Locking U-Ring Sets Include:			
		25 mm	76 mm	114 mm	140 mm	254 mm		Quantity & model numbers			
533	PRTS60	PRU11	PRU13	PRU14	-	PRU110	¹⁾ PRUS126	PRU11	PRU13	PRU14	-
							²⁾ PRUS137	PRU11	PRU13	PRU14	PRU110
889	PRTS60	PRU11	PRU13	PRU14	-	PRU110	¹⁾ PRUS126	PRU11	PRU13	PRU14	-
							²⁾ PRUS137	PRU11	PRU13	PRU14	PRU110
1333	PRTS150	PRU151	PRU153	-	PRU155	PRU1510	³⁾ PRUS1526	PRU151	PRU153	PRU155	-
							²⁾ PRUS1537	PRU151	PRU1510	PRU155	-
1778	PRTS200	PRU201	PRU203	-	PRU205	PRU2010	³⁾ PRUS2026	PRU201	PRU203	PRU205	-
							²⁾ PRUS2037	PRU201	PRU2010	PRU205	-

¹⁾ For 356 mm and 406 mm stroke models

²⁾ For 686 mm stroke models

³⁾ For 394 mm stroke models.

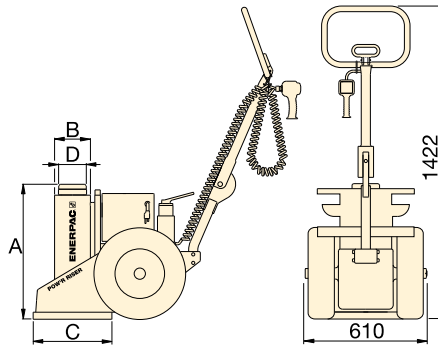

WARNING!

Extensions: Any two extensions may be stacked for loads up to 54 ton. For loads over 54 ton or strokes over 356 mm only one extension and one spacer can be used.

Spacers: Never exceed 76 mm in total spacer height.

Model Number with Air Pump	(kg)	A (mm)	B (mm)	C (mm)	D (mm)	Max. Additional Stack Height Using Optional Extension (mm)	Valve Type
PRAMA06014L	177	610	162	356	102	813*	Manual
PRAMA06027L	272	940	162	356	102	279	
PRAMA10016L	231	660	178	457	102	533**	
PRAMA10027L	272	940	178	457	102	279	
PRASA10016L	231	660	178	457	102	533**	Pneumatic
PRASA10027L	272	940	178	457	102	279	
PRASA15016L	258	660	203	457	127	533**	
PRASA15027L	321	940	203	457	127	279	Manual
-	-	660	203	457	127	533**	
-	-	940	203	457	127	279	
PRASA20016L	290	660	241	508	165	533**	Pneumatic
PRASA20027L	374	940	241	508	165	279	

* Based on one 457 mm and one 279 mm extension and one 76 mm spacer.

** Based on one 457 mm extension and one 76 mm spacer.

For power source, the following characters should be inserted in the 5th space of the model number.

Ordering Example:

Model No. PREME06014L is a 356 mm stroke, 54 ton model, with a manual valve and a 230 VAC, 1-ph, 50 Hz electric motor.

A Air Pump, 1416 l/min air consumption at 5,5 bar

B 115 VAC, 1-ph., 50-60 Hz, 20 A

E 208-240 VAC, 1-ph., 50-60 Hz, Euro Plug, 10 A

I 208-240 VAC, 1-ph., 50-60 Hz, USA Plug, 10 A

G ¹⁾ 208-240 VAC, 3-ph., 50-60 Hz

W ¹⁾ 380-415 VAC, 3-ph., 50-60 Hz

J ¹⁾ 440-480 VAC, 3-ph., 50-60 Hz

R ¹⁾ 575 VAC, 3-ph., 50-60 Hz.

¹⁾ Not available for 54 ton capacity.

▼ Shown: PL20025-ASA and PL20014-ASA



- Provides continuous locking protection during lift, lower and hold functions
- Patent-pending control technology synchronizes cylinder and lock nut for smooth and efficient lifting and lowering
- Unique double-acting cylinder offers a low collapsed height to accommodate more lifting applications
- Simple 2-button pendant allows operation of raise and lower functions from up to 6,1 metres away
- All load-bearing cylinder components have a nitrocarburized treatment to improve wear characteristics and resist corrosion
- Ergonomic handle has six positions for comfortable handling and folds when not in use
- Meets ANSI/ASME B30.1-2015, AS/NZS-2538, AS/NZS-2693 certification criteria.



Efficient Lifting with Continuous Automatic Load Locking



POW'R-LOCK™ Self-Locking Lift System

Only the POW'R-LOCK™ Lift System provides continuous positive locking of the load through all stages of lifting and lowering. No operator intervention is required to activate or de-activate the automatic locking system.

Two different stroke lengths are available. Both models are powered by an external compressed air system (user-supplied).

A convenient two-button pendant controls operation of the Lift System's air motor and directional control valve.



Tilt Load Cap

All POW'R-LOCK™ Lift System models feature a Tilt Load Cap to reduce side-loading.



Safety First

When lifting large, heavy vehicles certain precautions must be followed. Follow your published safety directions for lifting and cribbing your loads. The Pow'R-LOCK™ Lift System provides load/lock protection, but you must follow the safety directions for load cribbing operations.

◀ The PL-Series POW'R-LOCK™ Portable Lift System.

POW'R-LOCK™ Mobile Lift System



Accessories

Flat Load Cap – Non-tilt load cap has lower profile for tight lifting spaces.

Spacers – Minimize gap between load cap and lifting point to maximize hydraulic stroke of the jack.

Extensions – Stackable, with large alloy steel locating studs to resist effects of side-loading.

Extension Base Adapter – Extension Base Adapter design eliminates risk of improper stacking when using more than one extension.

PL Series



Rated Lifting Capacity:

181 ton

Stroke:

356 - 622 mm

Maximum Operating Pressure:

700 bar

Model Number	Description	Height (mm)	PL20014-ASA	PL20025-ASA
PLC1	Flat Load Cap	34	x	x
PLS1	Spacer	26	x	x
PLS2	Spacer	51	x	x
PLE5	Extension	127	x	x
	PLE7	Extension	178	x
	PLE9	Extension	229	x
	PLE11	Extension	280	x
PLE14	Extension	356	x	-
PLB12	Extension base adapter	305	x	-



WARNING!

PLE11 and PLE14 Extensions and PLB12 Extension Base Adapter are to be used with the "short" model **PL20014-ASA** only. Use of these extensions on the "tall" model **PL20025-ASA** will result in an excessive maximum lifting height. Load could become unstable and drop, resulting in possible personal injury and/or property damage.

Model Number	Maximum Additional Stack Height *
PLS20014-ASA	712 mm
PLS20025-ASA	229 mm

* Using optional PLB and PLE-Series extensions and PLS-Series spacers. Load cap height is NOT included in the stack height.

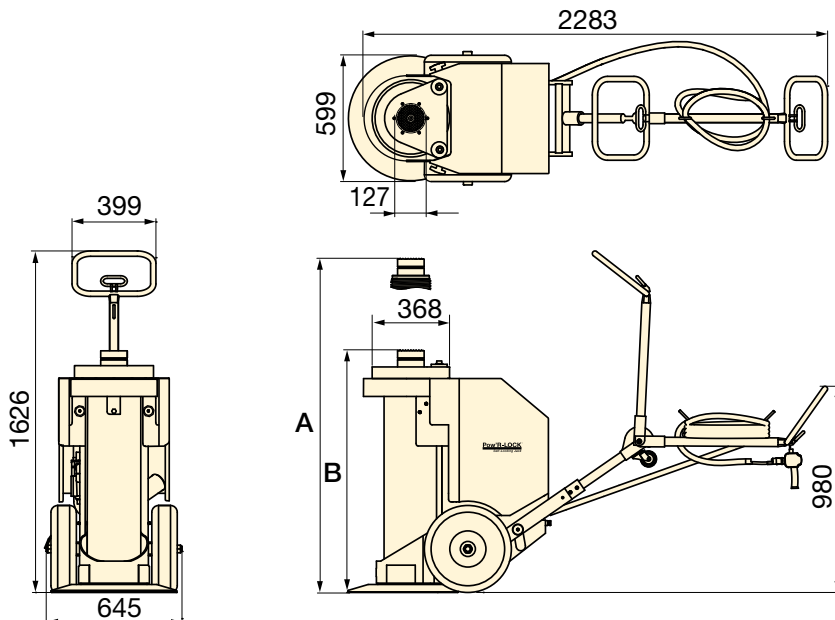

PR-Series, POW'R-RISER® Mobile Lifting Jack

When automatic load-locking is not required, the POW'R-RISER® jack provides a mobile lifting solution.

Page: 68

Capacity ton (kN)	Stroke (mm)	Model Nr. with Air Pump	Cylinder Lifting Speed ¹⁾ (mm/min)		Recommended Air Supply ²⁾		A ³⁾ (mm)	B ³⁾ (mm)	 (kg)
			Load	No Load	(l/min)	(bar)			
181 (1779)	356	PL20014-ASA	51	61	3681 - 4247	3,8 - 6,9	1219	864	501
	622	PL20025-ASA	51	61			1778	1156	599

¹⁾ Depending on available airflow, regulator setting, pump speed and load weight.

²⁾ Minimum dynamic air pressure of 3,8-4,1 bar. 6,2-6,9 bar required to achieve 1779 kN capacity.

³⁾ Height A and B are with Swivel Load Cap installed. Subtract 51 mm if flat load cap is used.

There's no substitute for experience in customizing hydraulic cylinders and Enerpac meets the needs of the most demanding applications.

Cylinders are the primary workhorse in hydraulic systems required to push or pull. Although Enerpac offers a wide variety of cylinders to fit many application requirements, there are many applications that require customization.

These may include special corrosion protection, ability to handle extreme side loads, or having special mounting needs.



◀ Large capacity, double-acting lock nut cylinders with an external lock ring used for bridge work.



◀ Double-acting cylinders with pilot-operated check valves and rod eyes on both ends for lifting and positioning applications.



◀ Custom private-label cylinders for OEM applications.

Overview Custom Cylinders



▲ Custom 500 ton double-acting cylinders with 1,83 m stroke for lifting electric rope shovels.

CUSTOMIZABLE FEATURES:

- Stroke
- Capacity
- Paint
- Pressure Rating
- Fitting
- Special Attachments
- Seals
- Imbedded Sensors
- Collapsed Height
- Rod Modifications
- Special Mounting
- Corrosion Resistance



Custom Hydraulic Pumps

Enerpac offers a wide variety of hydraulic pumps for all your custom needs. Still, many applications require a customized pump to operate the system.