

PULLERS

Concentrated power forged from steel: Pullers effortlessly move loads weighing several tonnes. Whenever components such as roller bearings, gear wheels or other machine elements need to be safely released from the friction-locked connection.

In industry and trade, stuck connections of pressed-on components that are held in position by their own frictional force are part of work life. GEDORE pullers are

the perfect choice for loosening them effortlessly and gently. Over 100 years of manufacturing expertise are reflected in the intelligent design and well thought-out components.

External and internal extractors, ball bearing extractors, special tools for the automotive sector and accessories such as nut splitters, flange drivers, thread adapters and safety foils. The GEDORE range covers the complete range of applications from 0.5 - 15 tonnes in workshops, industry, agricultural and construction machinery repair.



BEST QUALITY FOR YOUR SAFETY

- Maximum value is attached to the safety of the puller when selecting the material and manufacturing process for each individual component part beforehand.
- Any overloading of drop-forged components, such as 2-arm cross-beams, legs and clamping parts, is revealed through deformation - on account of the course of their fibres - rather than through fracturing and/or splintering.
- Thermo-chemical treatment bestows a hardness on the components meeting the demands placed.
- Strict checks ensure a constant high quality



SECURE INTELLIGENT

GEDORE PULLERS FOR MAXIMUM PERFORMANCE

- High-grade industrial quality for the toughest forms of continuous use and safety in everyday work
- Many years of experience in the development and production of puller tools
- numerous patents and utility models,
- Effortless moving of multi-ton loads
- Ideal for the controlled use of force and a vital requirement for safe working: puller in association with a torque wrench



GEDORE SPINDLE

- Maintenance free
- Fine thread is rolled and obtains higher strength
- Nitocarbursed surface makes them wear-resistant
- Oil and grease not necessary
- Spindle tips can be replaced

INTELLIGENT DESIGNS - WELL THOUGHTOUT COMPONENTS

- GEDORE pullers impress as much through their quality as they do through their user-friendliness and superiority in detail:
- A lasered scale on the 2-arm cross-beam enable the legs to be symmetrically aligned
- Leg brake and quick-release clamp are those rapid and assured ways of locking and fastening the puller legs
- Both the nitro-carburised mechanical and hydraulic spindles have properties that make work considerably easier and safer

i 1.04

A thoroughly superior puller

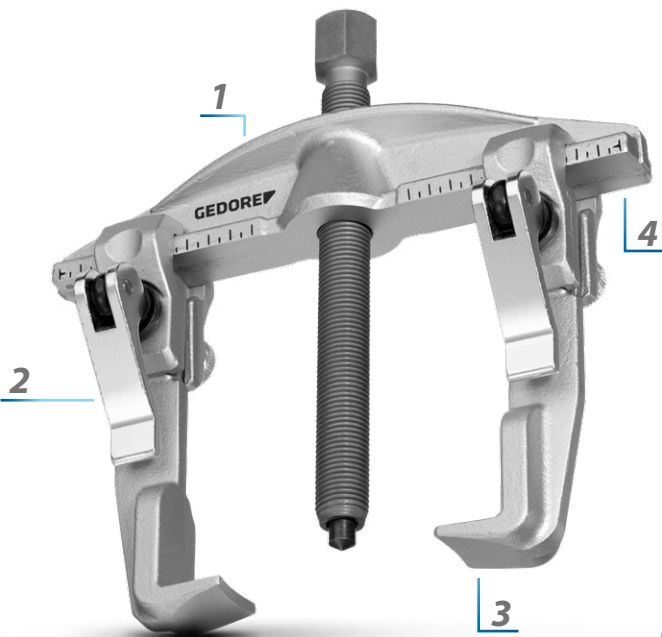

1

Reinforced cross-beam - the additional arching at the top of the crossbar produces an H-profile which, in turn, raises the load capacity as against the flexural torque.



2

The legs of the 1.04 puller series have a T-profile. This ensures a positive fit between leg and cross-beam. The T-profile transfers the tensile force of the hooks via the clamping parts to the cross-beam - with no losses involved. The quick release adjuster makes for trouble-free setting and readjustment.

3

Series 1.04 cross-beams, legs and clamping parts are hot drop-forged from hardened and tempered steel, giving them all the benefits of drop-forged components.



4

The permanently lasered scale makes it easier to symmetrically align the legs. This effectively stops any tilting when extracting caused by incorrectly positioned legs. A final marking specifies the maximum clamping spread.

1.04 Universal puller 2-arm pattern

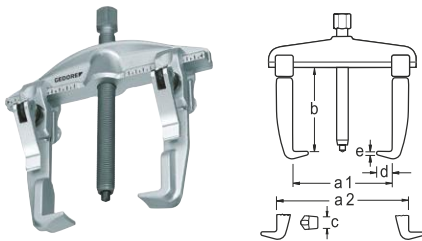

- > Strong truss with bending moment reinforcement
- > Adjustment scale for even adjustment of the puller hooks

- > Hook with quick adjustment

Code	No.	a1	a2 min	a2 max	b	max. t				optional	c	d	e		
1307703	1.04/1A	130	70	170	100	3	M14x1,5x140	17 mm	-		22	12	3,0	x	1,2
1307827	1.04/2A	200	110	260	150	5	G1/2x210	22 mm	1.06/HSP1		30	18	3,5	x	3,4
1307940	1.04/3A	350	150	420	200	7,5	G3/4x280	27 mm	1.06/HSP2		36	28	6,5	x	7,7

1.04/B Universal puller 2-arm pattern, rigid legs w/leg brake

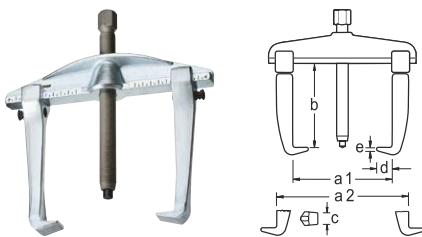

- > Strong truss with bending moment reinforcement
- > Pulling legs forged from one piece
- > With leg brake

- > Adjustment scale for even adjustment of the puller hooks

Code	No.	a1	a2 min	a2 max	b	max. t				optional	c	d	e		
1981110	1.04/1A-B	130	70	170	100	3	M14x1,5x140	17 mm	-		22	15	3,0	x	1,2
1981129	1.04/2A-B	200	110	260	150	5	G1/2x210	22 mm	1.06/HSP1		30	24	3,5	x	3,4
1981137	1.04/3A-B	350	150	420	200	7,5	G3/4x280	27 mm	1.06/HSP2		36	33	5,0	x	7,7

i 1.04 HIGH POWER

The power pack

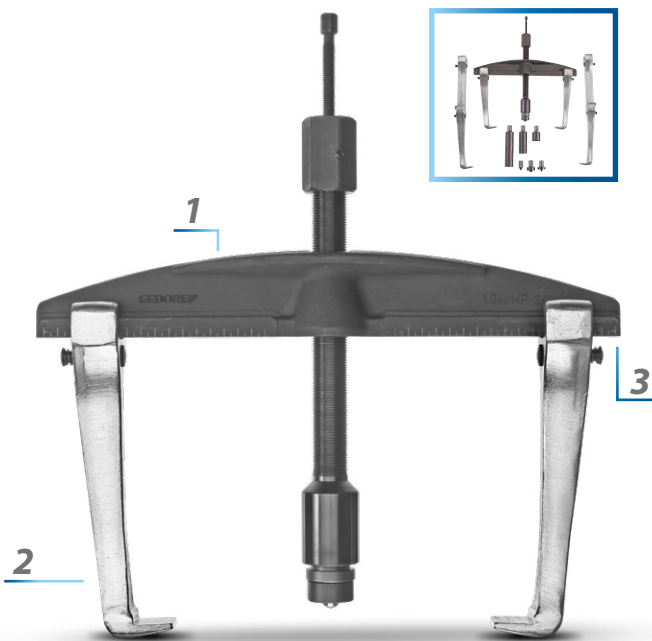

1

Reinforced cross-beam - the additional arching at the top of the crossbar produces an H-profile which, in turn, raises the load capacity as against the flexural torque. In the HP version the cross-beam is additionally hardened and tempered. This brings about practically a doubling of the loading limit!



2

The all-in steel legs are hot forged in one piece from 31CrV3 steel and hardened/tempered. They provide a positive locking connection to the cross-beam. The leg brake secures the hooks from unintentional motions. Pressing the release button unlatches the locking - the leg can be moved on the cross-beam. Releasing the button causes the leg to jam tight on the cross-beam with slipping ruled out.



3

The permanently lasered scale makes it easier to symmetrically align the legs. This effectively stops any tilting when extracting caused by incorrectly positioned legs. A final marking specifies the maximum clamping spread.

1.04/HP

Universal puller HIGH POWER
2-arm pattern

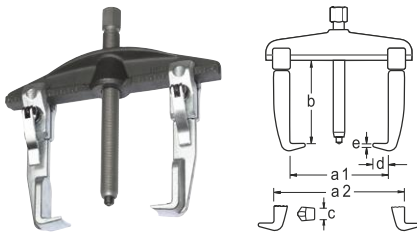

- > Spreader beam specially hardened and tempered, load with double traction force possible
- > Adjustment scale for even adjustment of the puller hooks

- > Integral legs, with quick-release

Code	No.	a1	a2 min	a2 max	b	max. t		mm	optional	c	d	e		
1868152	1.04/HP1A	130	70	170	100	5	M14x1,5x140	17 mm	-	22	12	3,0	x	1,2
1868160	1.04/HP2A	200	110	260	150	10	G1/2x210	22 mm	1.06/HSP1	30	18	3,5	x	3,4
1868179	1.04/HP3A	350	150	420	200	15	G3/4x280	27 mm	1.06/HSP2	36	28	6,5	x	7,7

1.04/HP-B

Universal puller HIGH POWER
2-arm pattern, rigid legs w/leg brake

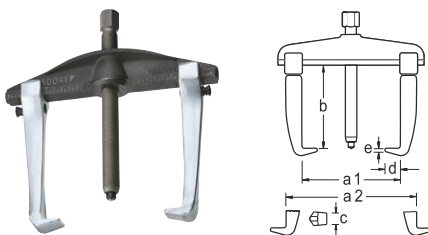

- > Spreader beam specially hardened and tempered, virtually doubles the load limit
- > Pulling legs forged from one piece
- > With leg brake

- > Adjustment scale for even adjustment of the puller hooks

Code	No.	a1	a2 min	a2 max	b	max. t		mm	optional	c	d	e		
1981145	1.04/HP1A-B	130	70	170	100	5	M14x1,5x140	17 mm	-	22	15	3,0	x	1,2
1981153	1.04/HP2A-B	200	110	260	150	10	G1/2x210	22 mm	1.06/HSP1	30	24	3,5	x	3,4
1981161	1.04/HP3A-B	350	150	420	200	15	G3/4x280	27 mm	1.06/HSP2	36	32	5,0	x	7,7

Puller

1.04/ST

Puller-Set with stand

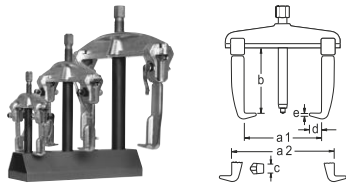

- > Consisting of 3 pullers in different sizes
- > Strong truss with bending moment reinforcement

- > Adjustment scale for even adjustment of the puller hooks
- > Hook with quick adjustment

Code	No.			
1675982	1.04/ST		1.04/1A Universal puller 2-arm 130x100 mm 1.04/2A Universal puller 2-arm 200x150 mm 1.04/3A Universal puller 2-arm 350x200 mm 1.04/97 Stand empty for 1.04 series	15,2

Code	No.	a1	a2 min	a2 max	b	max. t			optional	c	d	e		
1307703	1.04/1A	130	70	170	100	3	M14x1,5x140	17 mm	-	22	12	3,0	x	1,2
1307827	1.04/2A	200	110	260	150	5	G1/2x210	22 mm	1.06/HSP1	30	18	3,5	x	3,4
1307940	1.04/3A	350	150	420	200	7,5	G3/4x280	27 mm	1.06/HSP2	36	28	6,5	x	7,7

1101-1.04/SEB-08

Puller set, 2-arm pattern
9 pieces



- > Universal set incl. 2-arm puller, extensions, leg lengths, hooked feet for internal and external pulling
- > As a result of possible clamping reaches continuously up to 130 mm / clamping depths 10,0 100, 200, 250, 350 mm

- > Variable, rapid and safe working thanks to quick-clamp mechanism, leg brake, leg for confined spaces
- > 8 different pullers can be combined

Code	No.	Contents	
3106756	1101-1.04/SEB-08	i-BOXX 72 No. 1101 L + Assortment No. 1101 CT2-1.04	9,8

1.04/ST-HP-B

Puller-Set
with stand

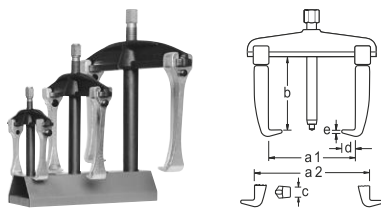

- > Consisting of 3 pullers in different sizes
- > Spreader beam specially hardened and tempered, virtually doubles the load limit
- > Pulling legs forged from one piece
- > With leg brake

- > Adjustment scale for even adjustment of the puller hooks

Code	No.			
2300044	1.04/ST-HP-B		1.04/HP1A-B Puller HIGH POWER 2-armed 130x100 mm 1.04/HP2A-B Puller HIGH POWER 2-armed 200x150 mm 1.04/HP3A-B Puller HIGH POWER 2-armed 350x200 mm 1.04/97 Stand empty for 1.04 series	14,4

Code	No.	a1	a2 min	a2 max	b	max. t			optional	c	d	e		
1981145	1.04/HP1A-B	130	70	170	100	5	M14x1,5x140	17 mm	-	22	15	3,0	x	1,2
1981153	1.04/HP2A-B	200	110	260	150	10	G1/2x210	22 mm	1.06/HSP1	30	24	3,5	x	3,4
1981161	1.04/HP3A-B	350	150	420	200	15	G3/4x280	27 mm	1.06/HSP2	36	32	5,0	x	7,7



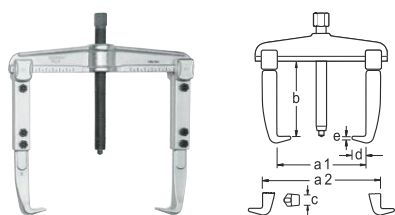

1.06

Universal puller
2-arm pattern, with extended legs



- > Adjustment scale for even adjustment of the puller hooks
- > Extended pulling legs

- > Interchangeable hooks available for several clamping depths

Code	No.	a1	a2 min	a2 max	b	max. t		 mm	 optional	c	d	e		
8108350	1.06/1-2	90	60	140	200	3	M14x1,5x140	17 mm	-	22	12	3,0	x	1,7
8108430	1.06/1A-2	130	70	180	200	3	M14x1,5x140	17 mm	-	22	12	3,0	x	1,6
8108510	1.06/2-3	160	80	220	300	5	G1/2x210	22 mm	1.06/HSP1	30	18	3,5	x	4,4
8108780	1.06/2A-3	200	90	260	300	5	G1/2x210	22 mm	1.06/HSP1	30	18	3,5	x	4,5
8001200	1.06/3-3	250	125	330	300	7,5	G3/4x280	27 mm	1.06/HSP2	36	28	6,5	x	9,1
8109080	1.06/3-4	250	125	330	400	7,5	G3/4x280	27 mm	1.06/HSP2	36	28	6,5	x	10,0
8109320	1.06/3-5	250	125	330	500	7,5	G3/4x280	27 mm	1.06/HSP2	36	28	6,5	x	11,3
8108860	1.06/3A-3	350	125	420	300	7,5	G3/4x280	27 mm	1.06/HSP2	36	28	6,5	x	9,8
8109160	1.06/3A-4	350	125	420	400	7,5	G3/4x280	27 mm	1.06/HSP2	36	28	6,5	x	11,1
8112380	1.06/3A-5	350	125	420	500	7,5	G3/4x280	27 mm	1.06/HSP2	36	28	6,5	x	12,2
8108940	1.06/4-3	520	185	600	300	10	G1x310	36 mm	1.06/HSP3	36	28	6,5	-	15,2
8109240	1.06/4-4	520	185	600	400	10	G1x310	36 mm	1.06/HSP3	36	28	6,5	-	16,4
8112460	1.06/4-5	520	185	600	500	10	G1x310	36 mm	1.06/HSP3	36	28	6,5	-	19,0

1.06/B

Universal puller
2-arm pattern, rigid legs w/leg brake

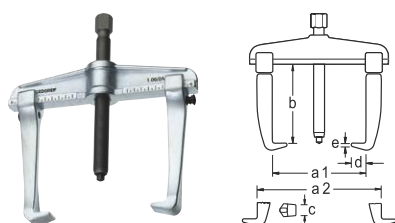

- > Pulling legs forged from one piece
- > With leg brake
- > Adjustment scale for even adjustment of the puller hooks

- > Interchangeable hooks available for several clamping depths

Code	No.	a1	a2 min	a2 max	b	max. t		 mm	 optional	c	d	e		
1956337	1.06/11-B	100	50	140	100	3,0	M 14x1,5x140	17 mm	-	22	15	3,0	x	0,9
1956345	1.06/1A1-B	140	60	180	100	3,0	M 14x1,5 x 140	17 mm	-	22	15	3,0	x	1,3
1956353	1.06/21-B	170	80	220	150	5,0	G 1/2 x 210	22 mm	1.06/HSP1	30	24	3,5	x	2,8
1956361	1.06/2A1-B	210	90	260	150	5	G 1/2 x 210	22 mm	1.06/HSP1	30	24	3,5	x	3,3
1956388	1.06/31-B	250	125	340	200	7,5	G 3/4 x 280	27 mm	1.06/HSP2	32	32	5,0	x	6,7
1956396	1.06/3A1-B	340	125	430	200	7,5	G 3/4 x 280	27 mm	1.06/HSP2	36	32	5,0	x	7,5
1958399	1.06/41-B	520	185	610	200	10	G 1 x 310	36 mm	1.06/HSP3	36	32	5,0	-	14,0

WWW.GEDORE.COM

1.06

Universal puller
2-arm pattern

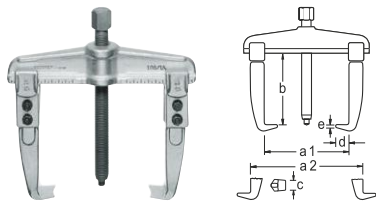

> Adjustment scale for even adjustment of the puller hooks

> Interchangeable hooks available for several clamping depths

Code	No.	a1	a2 min	a2 max	b	max. t		mm	optional	c	d	e		
8000230	1.06/1	90	60	140	100	3,0	M 14x1,5 x 140	17 mm	-	22	12	3,0	x	1,1
8000310	1.06/1A	130	70	180	100	3,0	M 14x1,5 x 140	17 mm	-	22	12	3,0	x	1,3
8000580	1.06/2	160	80	220	150	5,0	G 1/2 x 210	22 mm	1.06/HSP1	30	18	3,5	x	3,0
8000660	1.06/2A	200	90	260	150	5,0	G 1/2 x 210	22 mm	1.06/HSP1	30	18	3,5	x	3,5
8000740	1.06/3	250	125	330	200	7,5	G 3/4 x 280	27 mm	1.06/HSP2	36	28	6,5	x	7,2
8000820	1.06/3A	350	125	420	200	7,5	G 3/4 x 280	27 mm	1.06/HSP2	36	28	6,5	x	8,2
8000900	1.06/4	520	185	600	200	10	G 1 x 310	36 mm	1.06/HSP3	36	28	6,5	-	13,7

1.06/E

Quick release puller
2-arm pattern

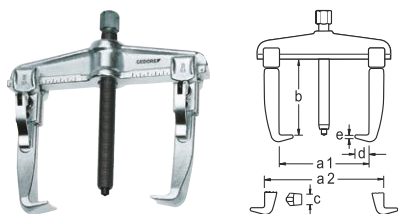

> Adjustment scale for even adjustment of the puller hooks
> Interchangeable hooks available for several clamping depths

> Hook with quick adjustment

Code	No.	a1	a2 min	a2 max	b	max. t		mm	optional	c	d	e		
1213830	1.06/1-E	90	60	140	100	3	M 14x1,5 x 140	17 mm	-	22	12	3,0	x	1,1
1215140	1.06/1A-E	130	70	180	100	3	M 14x1,5 x 140	17 mm	-	22	12	3,0	x	1,3
1216570	1.06/2-E	160	80	220	150	5	G 1/2 x 210	22 mm	1.06/HSP1	30	18	3,5	x	3,0
1217720	1.06/2A-E	200	90	260	150	5	G 1/2 x 210	22 mm	1.06/HSP1	30	18	3,5	x	3,5
1218980	1.06/3-E	250	125	330	200	7,5	G 3/4 x 280	27 mm	1.06/HSP2	36	28	6,5	x	7,1
1220160	1.06/3A-E	350	125	420	200	7,5	G 3/4 x 280	27 mm	1.06/HSP2	36	28	6,5	x	8,2

1.06/S-E

Quick release puller
2-arm pattern, with slim legs

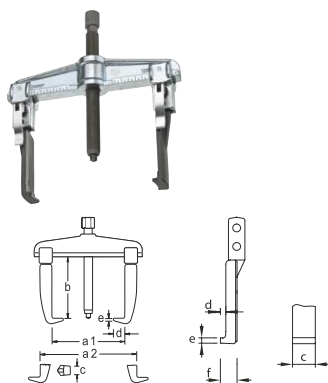

> The forged leg feet are very slim
> Adjustment scale for even adjustment of the puller hooks

> Hook with quick adjustment

Code	No.	a1	b	max. t		mm	optional	c	d	e	f		
2015706	1.06/S1-E	100	100	2	M 14x1,5 x 140	17 mm	-	29,8	7,5	3,7	13,5	x	1,1
2015714	1.06/S1A-E	140	100	2,5	M 14x1,5 x 140	17 mm	-	29,8	7,5	3,7	13,5	x	1,4
2015722	1.06/S2-E	160	150	5	G 1/2 x 210	22 mm	1.06/HSP1	40	7	5,0	15	x	2,9
2015730	1.06/S2A-E	200	150	5	G 1/2 x 210	22 mm	1.06/HSP1	40	7	5,0	15	x	3,6



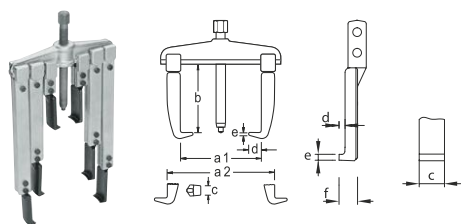

1.06/AS

Puller-Set
with 6 legs



> 2-arm puller, with 6 slender hooks in 3 lengths

> Particularly suitable for hard-to-reach areas

Code	No.	a	b	max. t		 mm	 optional	c	d	e	f		
8001710	1.06/AS	130	100 / 200 / 250	2,5	M 14x1,5 x 140	17 mm	-	29,5	7,5	3,7	13,5	1	3,4
1675974	1.06/AS-2	260	150 / 220 / 300	5,0	G 1/2 x 210	22 mm	1.06/HSP1	40	7	5,0	15		8,1

1.06/ST

Puller-Set
with stand

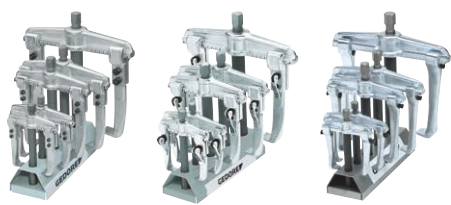

1.06/ST



1.06/ST-E

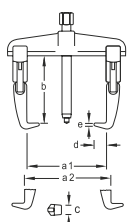



1.06/ST1-B



> Consisting of 5 pullers in different sizes with standard or quick-release pulling hook or all-steel hook with hook brake

> Adjustment scale for even adjustment of the puller hooks
> For clamping depths up to Ø 250 mm external, Ø 330 mm internal, and clamping reach up to 200 mm

Code	No.		
8111570	1.06/ST	1.06/1 1.06/1A 1.06/2 1.06/2A 1.06/3	19,0
1322745	1.06/ST-E	1.06/1-E 1.06/1A-E 1.06/2-E 1.06/2A-E 1.06/3-E	19,2
2004569	1.06/ST1-B	1.06/11-B 1.06/1A1-B 1.06/21-B 1.06/2A2-B 1.06/31-B	17,2

Code	No.	a1	a2 min	a2 max	b	max. t		 mm	 optional	c	d	e		
8000230	1.06/1	90	60	140	100	3,0	M 14x1,5 x 140	17 mm	-	22	12	3,0	x	1,1
8000310	1.06/1A	130	70	180	100	3,0	M 14x1,5 x 140	17 mm	-	22	12	3,0	x	1,3
8000580	1.06/2	160	80	220	150	5,0	G 1/2 x 210	22 mm	1.06/HSP1	30	18	3,5	x	3,0
8000660	1.06/2A	200	90	260	150	5,0	G 1/2 x 210	22 mm	1.06/HSP1	30	18	3,5	x	3,5
8000740	1.06/3	250	125	330	200	7,5	G 3/4 x 280	27 mm	1.06/HSP2	36	28	6,5	x	7,2
1213830	1.06/1-E	90	60	140	100	3	M 14x1,5 x 140	17 mm	-	22	12	3,0	x	1,1
1215140	1.06/1A-E	130	70	180	100	3	M 14x1,5 x 140	17 mm	-	22	12	3,0	x	1,3
1216570	1.06/2-E	160	80	220	150	5	G 1/2 x 210	22 mm	1.06/HSP1	30	18	3,5	x	3,0
1217720	1.06/2A-E	200	90	260	150	5	G 1/2 x 210	22 mm	1.06/HSP1	30	18	3,5	x	3,5
1218980	1.06/3-E	250	125	330	200	7,5	G 3/4 x 280	27 mm	1.06/HSP2	36	28	6,5	x	7,1
1956337	1.06/11-B	100	50	140	100	3,0	M14x1,5x140	17 mm	-	22	15	3,0	x	0,9
1956345	1.06/1A1-B	140	60	180	100	3,0	M 14x1,5 x 140	17 mm	-	22	15	3,0	x	1,3
1956353	1.06/21-B	170	80	220	150	5,0	G 1/2 x 210	22 mm	1.06/HSP1	30	24	3,5	x	2,8
1956361	1.06/2A1-B	210	90	260	150	5	G 1/2 x 210	22 mm	1.06/HSP1	30	24	3,5	x	3,3
1956388	1.06/31-B	250	125	340	200	7,5	G 3/4 x 280	27 mm	1.06/HSP2	32	32	5,0	x	6,7

1.07

Universal puller
3-arm pattern

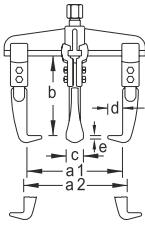

- > Even load distribution over 3 legs ensures secure grip and balanced pull
- > Strong, ergonomically shaped cross beam
- > Pull-off hook with screw connection

- > Interchangeable hooks available for several clamping depths

Code	No.	a1	a2 min	a2 max	b	max. t				optional	c	d	e	
8113940	1.07/1	90	70	140	100	3	M 14x1,5 x 140	17 mm	-		22	12	3,0	1,4
8114080	1.07/1A	130	80	180	100	3	M 14x1,5 x 140	17 mm	-		22	12	3,0	1,6
8114160	1.07/2	160	100	220	150	5	G 1/2 x 210	22 mm	1.06/HSP1		30	18	3,5	3,6
8114240	1.07/2A	200	100	260	150	5	G 1/2 x 210	22 mm	1.06/HSP1		30	18	3,5	4,2
1541757	1.07/3	250	100	400	200	7,5	G 3/4 x 280	27 mm	1.06/HSP2		36	28	6,5	9,3

1.07/B

Universal puller
3-arm pattern, rigid legs w/leg brake

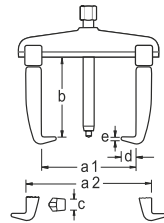

- > Even load distribution over 3 legs ensures secure grip and balanced pull
- > Pulling legs forged from one piece
- > With leg brake

- > Interchangeable hooks available for several clamping depths

Code	No.	a1	a2 min	a2 max	b	max. t				optional	c	d	e	
1957945	1.07/11-B	90	70	140	100	3	M 14x1,5 x 140	17 mm	-		22	15	3,0	1,2
1957953	1.07/1A1-B	130	80	180	100	3	M 14x1,5 x 140	17 mm	-		22	15	3,0	1,4
1957961	1.07/21-B	160	100	220	150	5	G 1/2 x 210	22 mm	1.06/HSP1		30	24	3,5	3,5
1957988	1.07/2A1-B	200	100	260	150	5	G 1/2 x 210	22 mm	1.06/HSP1		30	24	3,5	3,7
1957996	1.07/31-B	250	100	400	200	7,5	G 3/4 x 280	27 mm	1.06/HSP2		36	28	6,5	8,0

1.07/E

Quick release puller
3-arm pattern

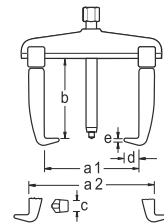

- > Industrial quality, 3 arms for optimum load distribution, non-tilting and gentle on material
- > Strong, ergonomically shaped cross beam
- > Self-supporting hooks with T-profile for a form-fit connection

- > Hook with quick adjustment

Code	No.	a1	a2 min	a2 max	b	max. t				optional	c	d	e	
1222902	1.07/1-E	90	70	140	100	3	M 14x1,5 x 140	17 mm	-		22	12	3,0	1,4
1225901	1.07/1A-E	130	80	180	100	3	M 14x1,5 x 140	17 mm	-		22	12	3,0	1,6
1227335	1.07/2-E	160	100	220	150	5	G 1/2 x 210	22 mm	1.06/HSP1		30	18	3,5	3,8
1227459	1.07/2A-E	200	100	260	150	5	G 1/2 x 210	22 mm	1.06/HSP1		30	18	3,5	4,0
1554751	1.07/3-E	250	100	400	200	7,5	G 3/4 x 280	27 mm	1.06/HSP2		36	28	6,5	9,2



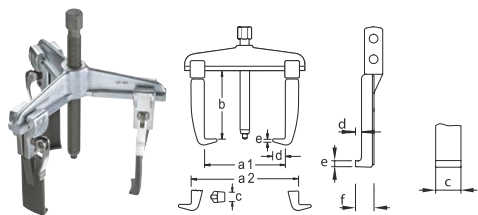

1.07/S-E

Quick release puller
3-arm pattern, with slim legs



- > Industrial quality, 3 arms for optimum load distribution, non-tilting and gentle on material
- > Strong, ergonomically shaped cross beam
- > Self-supporting hooks with T-profile for a form-fit connection

- > Slim forged hook feet
- > Hook with quick adjustment

Code	No.	a1	b	max. t		 mm	 optional	c	d	e	f	
2016036	1.07/S1-E	90	100	2,5	M 14x1,5 x 140	17 mm	-	29,5	7,5	3,7	13,5	1,3
2016044	1.07/S1A-E	130	100	2,5	M 14x1,5 x 140	17 mm	-	29,5	7,5	3,7	13,5	1,4
2016052	1.07/S2-E	160	150	5	G 1/2 x 210	22 mm	1.06/HSP1	40	7	5,0	15	3,6
2016060	1.07/S2A-E	200	150	5	G 1/2 x 210	22 mm	1.06/HSP1	40	7	5,0	15	3,9



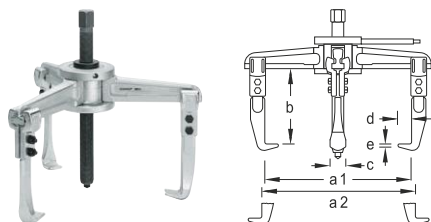

1.07/4

Universal puller
2-/3-arm pattern



- > Industrial quality, 3 arms for optimum load distribution, non-tilting and gentle on material
- > Strong, ergonomically shaped cross beam

- > Pull-off hook with screw connection

Code	No.	a1 max.	a1 min.	a2 max.	a2 min.	b	max. t		 mm	 optional	c	d	e	
8002440	1.07/4	450	150	530	270	200	10	G 1 x 360	36 mm	1.06/HSP3	36	28	6,5	18,8
1305085	1.07/4-3	450	150	530	270	300	10	G 1 x 360	36 mm	1.06/HSP3	36	28	6,5	21,2
1305425	1.07/4-5	450	150	530	270	500	10	G 1 x 360	36 mm	1.06/HSP3	36	28	6,5	25,2
1958003	1.07/4A	580	150	640	270	200	10	G 1 x 360	36 mm	1.06/HSP3	36	28	6,5	23,0
2302802	1.07/4A-4	580	150	640	270	400	10	G 1 x 360	36 mm	1.06/HSP3	36	28	6,5	25,8
2302810	1.07/4A-5	580	150	640	270	500	10	G 1 x 360	36 mm	1.06/HSP3	36	28	6,5	28,4



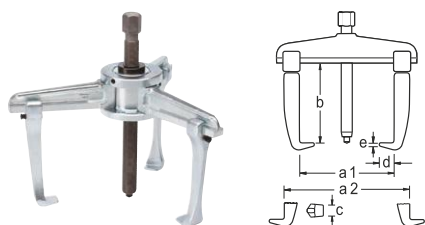

1.07/4-B

Universal puller
2-/3-arm pattern, rigid legs w/leg brake



- > Industrial quality, 3 arms for optimum load distribution, non-tilting and gentle on material
- > Strong, ergonomically shaped cross beam
- > Pulling legs forged from one piece

- > With leg brake

Code	No.	a1 max.	a1 min.	a2 max.	a2 min.	b	max. t		 mm	 optional	c	d	e	
2546531	1.07/41-B	450	150	530	270	200	10	G 1" x 360	36 mm	1.06/HSP3	36	28	6,5	18,8
2546558	1.07/4A1-B	580	150	640	270	200	10	G 1" x 360	36 mm	1.06/HSP3	36	28	6,5	22,0

Puller

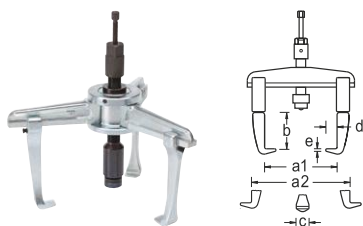

1-O7/4-B-HSP

Universal puller
hydraulic, 2-/3-arm pattern,
rigid legs w/leg brake



- > Industrial quality, 3 arms for optimum load distribution, non-tilting and gentle on material
- > Strong, ergonomically shaped cross beam
- > Pulling legs forged from one piece
- > With leg brake

- > Hydraulic spindle with hardened surface, wear resistant
- > Safety note: Controlled removal is guaranteed by using a torque wrench

Code	No.	a1 max.	a1 min.	a2 max	a2 min	b	max. t	max. Nm		c	d	e	
2546574	1.07/41-B-HSP3	450	150	530	270	140	10	25,0	1.06/HSP3	36	28	6,5	19,9
2546582	1.07/4A1-B-HSP3	580	150	640	270	140	10	25,0	1.06/HSP3	36	28	6,5	23,1



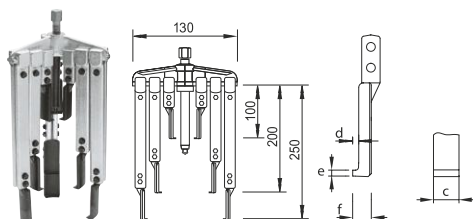

1.07/AS

Puller-Set
with 9 legs



- > 3-arm puller, with 9 slim hooks in 3 lengths

- > Particularly suitable for hard-to-reach areas

Code	No.	a	b	max. t		 mm	 optional	c	d	e	f	
8117260	1.07/AS	130	100 / 200 / 250 mm	2,5	M 14x1,5 x 140	17 mm	-	29,5	7,5	3,7	13,5	4,9
1675990	1.07/AS-2	200	150 / 220 / 300 mm	5,0	G 1/2 x 210	22 mm	1.06/HSP1	40	7	5,0	15	11,5



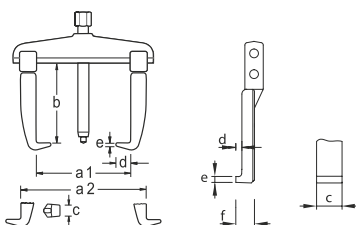

1.07/K

Puller-Set
with 9 legs



- > In robust plastic case
- > Contents: 1 spindle, 1 cross-beam each 2- and 3-arm pattern and 9 slim pulling legs in 3 lengths

- > 2. spindle in case 1.07/K saves working time

Code	No.	a	b	max. t		 mm	 optional	c	d	e	
8117340	1.07/K	130	100 / 200 / 250 mm	2,5		17 mm	-	27	7,5	3,7	5,8
1676008	1.07/K-2	200	150 / 220 / 300 mm	5,0	G 1/2 x 210	22 mm	1.06/HSP1	40	7	5,0	13,5



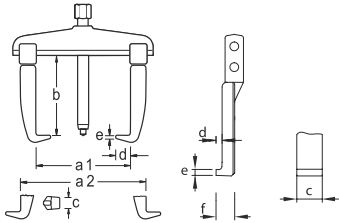

1.07/K-SE

Puller-Set
with 3 legs



- > In robust plastic case
- > Contents: 1 spindle, 1 cross-beam each 2- and 3-arm pattern and 3 quick-release pulling legs

> 2. spindle in case 1.07/K-1-SE saves working time

Code	No.	a	b	max. t		 mm	 optional	c	d	e	
1438484	1.07/K-1-SE	90	100	2,5	M 14x1,5 x 140	17 mm	-	27	7	3,7	2,2
1645455	1.07/K-2-SE	160	150	5,0	G 1/2 x 210	22 mm	1.06/HSP1	40	7	5,0	5,5

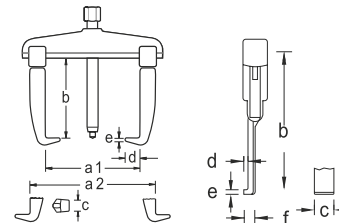

1.07/K-SE S

Puller-Set
with 6 legs



- > In robust plastic case
- > The forged hooked feet are particularly suitable for difficult-to-access places
- > hook with quick adjustment

> Contents: 2 spindles, 1 cross-beam each 2- and 3-arm pattern thin quick-grip pulling legs of the 100 and 200 mm clamping depths

Code	No.	a	b	max. t		 mm	c	d	e	
1745158	1.07/K-1-SE 200 S	90	100 - 200 mm	2,5	M 14x1,5 x 140	17 mm	27	7,5	3,7	4,2

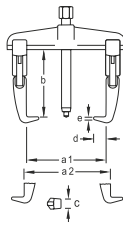

1.07/K-B

Puller-Set
with 3 legs, with leg brake



- > In robust plastic case
- > Contents: 2 spindles, 1 cross-beam each 2- and 3-arm pattern and 3 rigid legs with leg brake

> Second spindle saves working time

Code	No.	a	b	max. t		 mm	c	d	e	
2224097	1.07/K-1A-B	140	100	3,0	M14x1,5 x 140	17 mm	22	15	3,0	2,9

SUMMARY OF PULLER LEGS

106/xx-yy-zz

xx = Leg size (A-C)

yy = Leg length (in mm)

zz = Leg type

for 2-arm puller

for 3-arm puller

Mechanical replacement spindle

Hydraulic replacement spindle

A

1.04/1A...

1.04/HP1A...

1.06/1...

1.06/1A...

1.07/1...

1.07/1A...

M14x1,5

104/TE Quick-release pulling legs

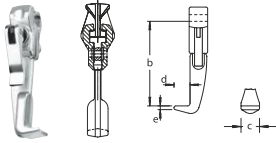

- > Quick release puller hook for puller No. 1.04

Code	No.	b	c	d	e	
1499351	104/A-100-TE	100	22	12	3,0	0,3

106/N Pulling leg THE PROVEN

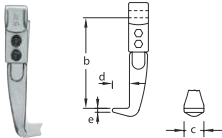

- > 1 hook incl. clamping pieces with proven screw connection in various lengths

Code	No.	b	c	d	e	
1120514	106/A-100-N	100	22	12	3,0	0,3
1120522	106/A-200-N	200	22	12	3,0	0,4

106/B Pulling leg THE STURDY

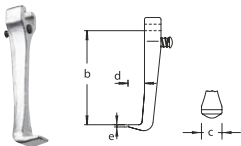

- > 1 hook with hook brake, with safety device against unintentional slipping, at the push of a button the hook can be moved on the crossbar, forged from one piece

Code	No.	b	c	d	e	
1970534	106/A-100-B	100	22	15	3,0	0,2

106/E Pulling leg THE QUICK

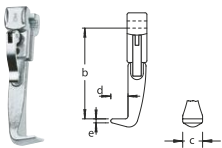

- > 1 hook incl. clamps with quick adjustment, quick and easy adjustment and readjustment of the hooks on the crossbar

Code	No.	b	c	d	e	
1178199	106/A-100-E	100	22	12	3,0	0,3

106/SE Pulling leg THE SLENDER

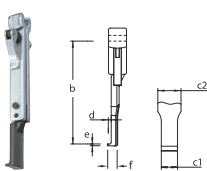

- > 1 extra slim leg incl. clamping parts with quick-release adjustment, for fast and uncomplicated setting and adjustment

Code	No.	b	c	d	e	f	
1438514	106/A-100-SE	100	27	7,5	3,7	13,5	0,3
2015757	106/A-200-SE	200	27	7,5	3,7	13,5	0,4
2015773	106/A-250-SE	250	27	7,5	3,7	13,5	0,6
2015781	106/A-100-SSE	100	27	7,5	2,0	13,5	0,3
2015811	106/A-200-SSE	200	27	7,5	2,0	13,5	0,5
2015846	106/A-250-SSE	250	27	7,5	2,0	13,5	0,6

106/XSE Pulling leg THE SOPHISTICATED

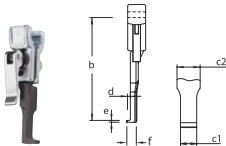

- > 1 extra slim leg incl. clamping parts with quick-release adjustment, for fast and uncomplicated setting and adjustment
- > Particularly suitable for barely accessible places, e.g. gear maintenance

Code	No.	b	c1	c2	d	e	f	
2018748	106/A-100-XSE	100	16	25	5	3,7	9,6	0,2

106/VB Extension leg with leg brake

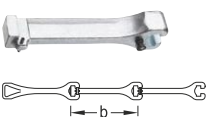

- > Using the extension between cross-beam and leg the clamping reach can be extended indefinitely
- > Forged from one piece
- > Extra safety through hook brake

Code	No.	b	
2329034	106/A-100-VB	100	0,2

106/S - 108/XS Loose legs

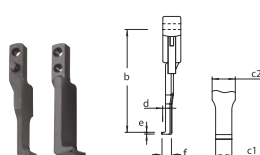

- > The small black
- > 1 slim leg foot for use in confined spaces
- > * S = Spare foot for THE SLIM
- > ** XS = Spare foot for THE FILIGREE

Code	No.	c	d	e	
1076957	E-106/S101	27	7,5	3,7	0,1
1495607	106/S101-S	27	7,5	2,0	0,1

Code	No.	c1	d	e	f	
2013681	106/XS101	16	5	3,7	9,6	0,1

B

1.04/2A...	1.04/HP2A...
1.06/2...	1.06/2A...
1.07/2...	1.07/2A...
G1/2"	
1.06/HSP1	

C

1.04/3A...	1.04/HP3A...	
1.06/3...	1.06/3A...	1.06/4...
1.07/3...		1.07/4... 1.07/4A...
G3/4"		G1" & M55x2
1.06/HSP2		1.06/HSP3

Code	No.	b	c	d	e	
1499378	104/B-150-TE	150	30	18	3,5	0,7

Code	No.	b	c	d	e	
1499386	104/C-200-TE	200	36	28	6,5	2,9

Code	No.	b	c	d	e	
1120530	106/B-150-N	150	30	18	3,5	0,7
1123947	106/B-300-N	300	30	18	3,5	1,3

Code	No.	b	c	d	e	
1120549	106/C-200-N	200	36	28	6,5	1,6
1120557	106/C-300-N	300	36	28	6,5	2,4
1120565	106/C-400-N	400	36	28	6,5	2,9
1120573	106/C-500-N	500	36	28	6,5	3,5

Code	No.	b	c	d	e	
1970542	106/B-150-B	150	30	24	3,5	0,6

Code	No.	b	c	d	e	
1970550	106/C-200-B	200	36	32	5,0	1,2

Code	No.	b	c	d	e	
1178253	106/B-150-E	150	30	18	3,5	0,7

Code	No.	b	c	d	e	
1178350	106/C-200-E	200	36	28	6,5	1,5

Code	No.	b	c	d	e	f	
2015862	106/B-220-SE	220	40	7	5,0	15	1,0
2015870	106/B-300-SE	300	40	7	5,0	15	1,2
1671499	106/B-150-SE	150	40	7	5,0	15	0,7

Code	No.	b	c1	c2	d	e	f	
2018756	106/B-150-XSE	150	17,5	32	5,5	3,5	11	0,6

Code	No.	b	
2329042	106/B-150-VB	150	0,6

Code	No.	b	
2329050	106/C-200-VB	200	1,3

i SPINDLES

GEDORE spindles ...

... require no maintenance!

- ... comprise turned hardened and tempered steel. The fine thread is then rolled - this additional strengthening of the steel gives rolled thread a higher strength than a thread produced by cutting.
- ... have a fine thread which stops any unintended slackening from vibrations.
- ... are thermo-chemically treated. Nitro carburating makes the spindle extremely wear resistant and corrosion-proof. Nitro-carburated surfaces have excellent sliding properties.
- ... **Oiling and greasing is not needed and**, as such, the thread stays clean and smooth much longer. (Resinated, used oil attracts dirt and chips like magic. The thread pitches clog and turning the thread is not easy - in the final resort, this results in ruination of the thread. Not to speak of that irksome task of regularly filling up with oil.)
- ... are fitted out with a replaceable spindle tip which is equally suitable for both centred and non-centred shafts*.

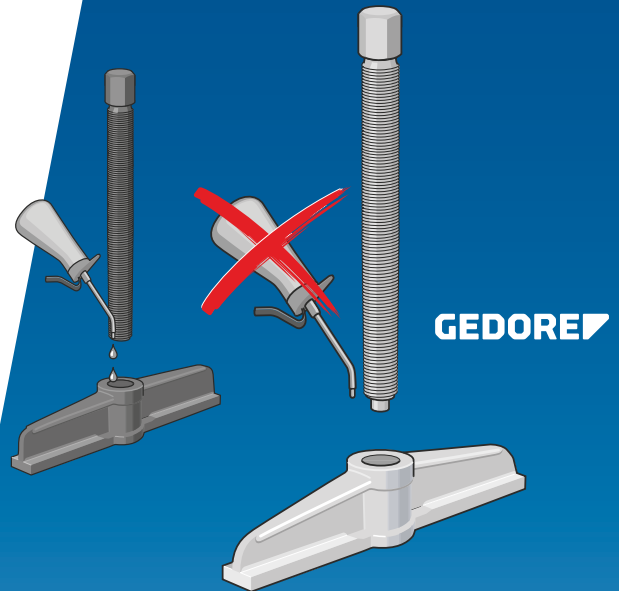

MECHANICAL SPINDLE, HYDRAULIC SPINDLE OR HYDRAULIC PRESS?

- The **mechanical spindles** of GEDORE pullers offer many advantages: made of heat-treated steel, fine thread rolled and thermochemically treated - making them particularly wear-resistant and corrosion-resistant.
- Especially with high forces, the use of a **hydraulic spindle** can save time and effort. The principle of the hydraulic spindle is as simple as it is genial: by screwing in the pressure screw, the grease inside the hydraulic piston is pressed - the extending piston acts on the part to be extracted with a multiple of the force applied manually above Gedore spindles ...

manually applied above on the part to be extracted. Due to this controlled mode of operation, the hydraulic spindle allows safe work and is and is particularly recommended for high forces.

- The **hydraulic press** is an alternative to the hydraulic spindle. It is mounted between the mechanical spindle and the shaft and supports the spindle with its hydraulic power.
- Pulling off with the support of hydraulic aids saves working time and power, as the puller cannot rotate during the pulling-off process.

* As standard with extractors Nos. 1.04 and No.1.09

1.06/HSP

Hydraulic pressure spindle

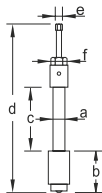

- > For controlled and safe pulling work
- > Set up for a compression of 10 t, 12 t or 15 t
- > The thrust piece can be replaced by a tip and extended if necessary

- > The small pressure spindle is secured with an unscrewing lock to stop any accidental withdrawal

Code	No.	a	max. t	max. Nm	b	c	d	e	f	Stroke	
8116100	1.06/HSP1	G 1/2"	10,0	17,0	80	135	350	12	32	12	1,1
8116290	1.06/HSP2	G 3/4"	12,0	19,0	80	205	420	12	36	12	1,8
8116370	1.06/HSP3	G 1"	15,0	33,0	125	165	465	17	41	12	3,4

1.06/HSP-V

Extension for hydraulic spindle



Code	No.	Usable length	↳ mm ↳	
2824787	1.06/HSP-35V	35	60	0,3
2824841	1.06/HSP-85V	85	110	0,6
2824868	1.06/HSP-135V	135	160	1,0

1.06/HSP-D

Pressure piece for hydraulic spindle



Code	No.	Version	
2824876	1.06/HSP12-DK	with ball	0,2
2824884	1.06/HSP12-DS	with tip	0,1
2824892	1.06/HSP12-DSK	with lace short	0,1
2824906	1.06/HSP3-DS	with tip	0,2

1.55

Hydraulic press



- > By using the hydraulic press, the performance of the normal pressure spindle is considerably increased
- > Important: Release the hydraulics after use

Code	No.	max. t	Stroke height	Installation height	
8024170	1.55/2	15,0	15	90	1,8

Spindle summary



- > KS = ball tip, exchangeable

* Pull spindle

Code	No.	Threads	Usable length	Drive	Ball tip	Ball Tip	
1084739	129.106	M 10x1,5	160	14	x		0,120
1084445	1.1206110	M 12x1,5	110	14		x	1,100
1084453	1.1406050	M 14x1,5	50	17		x	0,105
1084461	1.1406125	M 14x1,5	125	17		x	0,185
1084488	1.1406140	M 14x1,5	140	17		x	0,176
1546821	1.1406140KS	M 14x1,5	140	17	x	x	0,200
1084518	1.1406155	M 14x1,5	155	17		x	0,215
1576224	1.1406200	M 14x1,5	200	17		x	0,285
1084755	129.306	M 14x2,0	210	17	x		0,250
1084526	1.1806080	M 18x1,5	80	19		x	0,195
1084542	1.1806130	M 18x1,5	130	19		x	0,295
1084550	1.1806170	M 18x1,5	170	19		x	0,390
1084569	1.1806200	M 18x1,5	200	19		x	0,440
1084763	129.406	M 18x2,5	230	19	x		0,450
1084771	129.506	M 20x2,5	235	22	x		0,600
1084577	1.2106110	G 1/2"	110	22		x	0,340
1084585	1.2106160	G 1/2"	160	22		x	0,455
1084623	1.2106175	G 1/2"	175	22		x	0,535
1084593	1.2106210	G 1/2"	210	22		x	0,615
1546872	1.2106210KS	G 1/2"	210	22	x	x	0,615
1084631	1.2106250	G 1/2"	250	22		x	0,705
1795112	1.2106250KS	G 1/2"	250	22	x	x	0,680
1084658	1.2106350	G 1/2"	350	22		x	0,955
1806564	1.2106350KS	G 1/2"	350	22	x	x	0,010
1076132*	1.2106400	G 1/2"	400	16			1,100
1084666	1.2606180	G 3/4"	200	27		x	0,990
1084674	1.2606280	G 3/4"	280	27		x	1,280
1546910	1.2606280KS	G 3/4"	280	27	x	x	1,270
1084690	1.3306310	G 1"	310	36		x	2,285
1084704	1.3306360	G 1"	360	36		x	2,600
1084712	1.3306500	G 1"	500	36		x	3,600

Puller

1.80

Spindle pressure pads
for axle bores (hollow shafts)

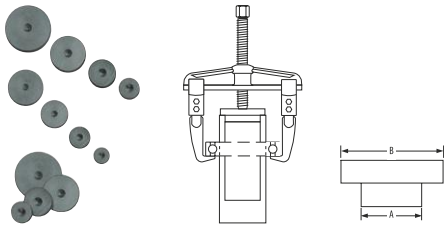

> For the removal of bearings and gear wheels that are mounted on hollow shafts or in housings

> The spindle pressure pad serves as a counter-axis to the puller, where the spindle now transfers the force to the pressure pad

Code	No.	A / Mounting-Ø	B / Plate-Ø	
1120697	1.80/1	19, 22, 25, 28, 32, 35, 38, 41, 44, 48, 50	25, 28, 32, 35, 41, 44, 48, 50, 54, 60, 64	2,3

1.85/1

Professional plastic bearing installation set
37 pieces



- > Using this bearing installation set more than 200 types of bearings may be re-installed effortlessly and without damage
- > The impact-resistant plastic is handily light, but just as robust as the metal variants
- > In rugged plastic case

Code	No.	Contents	Pieces	
1120778	1.85/1	33 impact rings, 10-50 mm for external Ø 26-110 mm 3 aluminium impact sleeves 1 recoil-free bodywork hammer with nylon heads (1.2 kg)	37	5,2

5.10

Safety cover Size 1



> With pull-off forces of up to 18 t, these PVC safety films offer maximum protection through active safety against suddenly shearing ball bearings, drive pinions or small components. The films are highly flexible and can therefore be used in all situations

> Double-layer welded = double safety (thickness of 0.5 mm = 1.0 mm)
> Tear strength: longitudinal 23 N/mm² - lateral 21 N/mm²
> 2 straps for variable adjustment



Code	No.	
1868195	5.10	1,5

i 1.09 TWIST & PULL

Easy, quick and safe

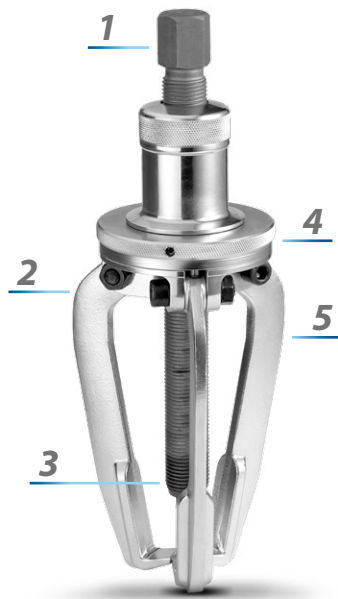

ADVANTAGES

- No setting-up or readjusting of the legs
- Maintenance-free due to encapsulated mechanics

1

Fast and accurate use through the precision manufactured head.

2

High-grade steel and thermo-chemical treatment assure high pressure load capacity for the spindle and tensile load capacity in the legs.

3

The flexible, interchangeable spindle tip is equipped for different applications.

4

The encapsulated mechanics are maintenance-free.

5

The legs open by a simple twisting movement and automatically surround the part to be withdrawn - can also be used for vertical applications. No readjustment necessary.

1.09
Puller TWIST + PULL
3-arm pattern, with rotating adjustment

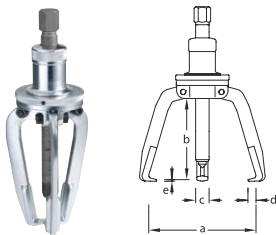

- > The precise manufactured head allows fast and exact use
- > The legs open by simple rotation and enclose automatically the part to be removed

- > No more time-consuming set-up and readjusting of the legs

Code	No.	a min	a max	b		mm	c	d	e	max. t	
1748173	1.09/1	30	150	130	G 1/2 x 250	22 mm	17	12	3,0	6,5	2,5
1748181	1.09/2	80	250	250	G 1/2 x 350	22 mm	24	12	3,0	6,5	4,2

1.10
Puller
2-arm pattern

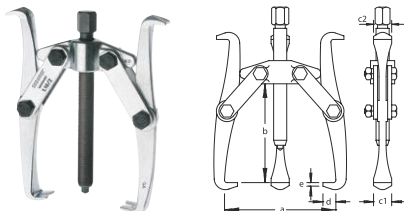

- > Tried and tested, strong design for removing discs, wheels, ball bearings etc.
- > The wide or narrow hook ends, which can be used on both sides, press themselves automatically when loaded

- > The wide leg ends of the puller 1.10/2, /3, /4 and /5 possess 8 mm slots, so that pulleys or gears may also be pulled off using 8 mm bolts

Code	No.	a max	b	max. t		mm	optional	c1	c2	d	e	
8002600	1.10/1	90	80	2	M 14x1,5 x 125	17 mm	-	17	10	7	2,0	0,7
8002790	1.10/2	160	130	5	M 18x1,5 x 170	19 mm	-	24	20	13	3,0	2,0
1731874	1.10/3	220	170	5	M 18x1,5 x 170	19 mm	-	24	20	13	3,0	2,3
1731882	1.10/4	320	260	8	G 1/2 x 350	22 mm	1.06/HSP1	27	32	27	6,5	5,1
1731890	1.10/5	400	320	8	G 1/2 x 350	22 mm	1.06/HSP1	27	32	27	6,5	5,8



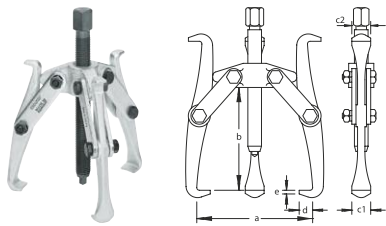

Puller

1.11 Puller 3-arm pattern



- > Tried and tested, strong design for removing discs, wheels, ball bearings, etc.
- > The wide or narrow hook ends, which can be used on both sides, press themselves automatically when loaded

- > The wide leg ends of the puller 1.11/2, /3, /4 and /5 possess 8 mm slots, so that pulleys or gears may also be pulled off using 8 mm bolts

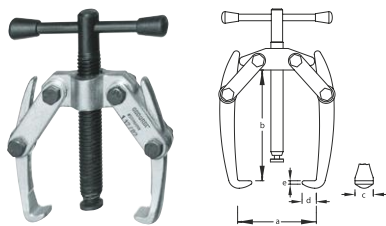

Code	No.	a max	b	max. t			 optional	c1	c2	d	e	
8002950	1.11/1	90	80	3	M 14x1,5 x 125	17 mm	-	17	10	7	2,0	0,9
8003090	1.11/2	160	130	7.5	M 18x1,5 x 170	19 mm	-	24	20	13	3,0	2,6
1731904	1.11/3	220	170	7.5	M 18x1,5 x 170	19 mm	-	24	20	13	3,0	3,2
1731912	1.11/4	320	260	12	G 1/2 x 350	22 mm	1.06/HSP1	27	32	27	6,5	5,8
1731920	1.11/5	400	320	12	G 1/2 x 350	22 mm	1.06/HSP1	27	32	27	6,5	8,0

1.12 Battery-terminal puller 2-arm pattern



- > Ideal for removing small parts such as battery terminals, pulleys, wheels, ball bearings, etc.

- > The legs grip automatically

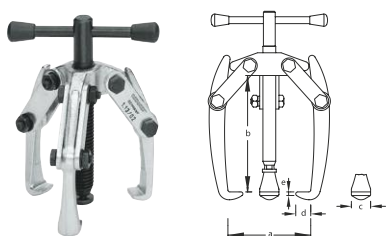

Code	No.	a max	b	max. t		c	d	e	
8003840	1.12/02	60	40	0.5	M 10x1,5 x 60	10	5	2,0	0,2
8003760	1.12/01	60	60	0.5	M 10x1,5 x 80	10	5	2,0	0,2
1628402	1.12/00	70	80	0.5	M 10x1,5 x 100	14	8	2,0	0,3

1.13 Battery-terminal puller 3-arm pattern



- > Ideal for removing small parts such as battery terminals, pulleys, wheels, ball bearings, etc.

- > The legs grip automatically

Code	No.	a max	b	max. t		c	d	e	
8004650	1.13/02	60	40	0.75	M 10x1,5 x 60	10	5	2,0	0,2
8004570	1.13/01	60	60	0.75	M 10x1,5 x 80	10	5	2,0	0,2
1628410	1.13/00	70	80	1	M 10x1,5 x 100	14	8	2,0	0,4



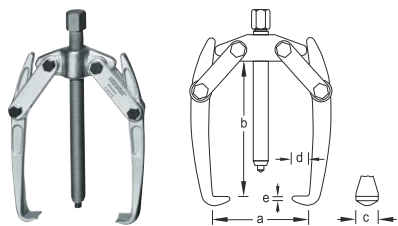

1.12

Puller
2-arm pattern



- > Handy robust model for the removal of pulleys, wheels, ball bearings, etc.
- > Inexpensive economy model

> The legs grip automatically

Code	No.	a max	b	max. t		 mm	 optional	c	d	e	
8003250	1.12/0	70	80	1	M 12x1,5 x 110	14 mm	-	14	8	2,0	0,4
8003330	1.12/1	90	120	2	M 14x1,5 x 155	17 mm	-	18	11	2,5	0,8
8003410	1.12/2	130	160	5	M 18x1,5 x 200	19 mm	-	25	14	3,0	1,9
8003680	1.12/3	180	200	8	G 1/2 x 250	22 mm	1.06/HSP1	32	20	4,0	3,7



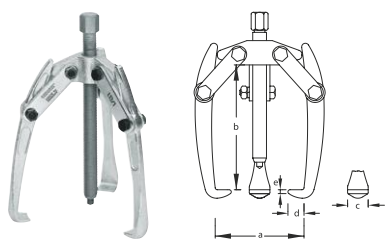

1.13

Puller
3-arm pattern



- > Handy robust model for the removal of pulleys, wheels, ball bearings, etc.
- > Inexpensive economy model

> The legs grip automatically

Code	No.	a max	b	max. t		 mm	 optional	c	d	e	
8004140	1.13/0	70	80	2	M 12x1,5 x 110	14 mm	-	14	8	2,0	0,5
8004220	1.13/1	90	120	3	M 14x1,5 x 155	17 mm	-	18	11	2,5	1,5
8004300	1.13/2	130	160	7.5	M 18x1,5 x 200	19 mm	-	25	14	3,0	2,5
8004490	1.13/3	180	200	12	G 1/2 x 250	22 mm	1.06/HSP1	32	20	4,0	5,3

WWW.GEDORE.COM



Puller

1.14 Puller 2-arm pattern



- > Tried and tested, particularly strong design for removing discs, wheels, ball bearings etc.
- > With technical and economical benefits due to the variable clamping reach and automatic grip of the legs

- > Particularly suitable for pulling off V-belt pulleys and flywheels which are mounted on longer shafts
- > Upgradeable with hydraulic spindle



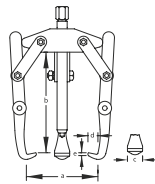

Code	No.	a max	b	max. t		 mm	 optional	c	d	e	
8004810	1.14/0	90	100	1	M 12x1,5 x 110	14 mm	-	14	9	2,0	0,4
8005030	1.14/1	130	140	2	M 14x1,5 x 140	17 mm	-	18	11	2,0	0,9
8005380	1.14/2	200	210	5	M 18x1,5 x 200	19 mm	-	25	16	3,0	2,2
8005460	1.14/3	250	260	8	G 1/2 x 250	22 mm	1.06/HSP1	32	18	3,5	4,4
8005540	1.14/4	280	390	8	G 1/2 x 250	22 mm	1.06/HSP1	32	20	3,5	5,1
8005620	1.14/5	420	480	8	G 1/2 x 350	22 mm	1.06/HSP1	32	20	3,5	6,0

1.15 Puller 3-arm pattern



- > Tried and tested, particularly strong design for removing discs, wheels, ball bearings etc.
- > With technical and economical benefits due to the variable clamping reach and automatic grip of the legs

- > Particularly suitable for pulling off V-belt pulleys and flywheels which are mounted on longer shafts
- > Upgradeable with hydraulic spindle

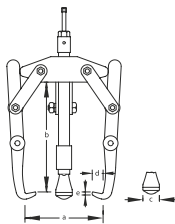

Code	No.	a max	b	max. t		 mm	 optional	c	d	e	
8006000	1.15/0	90	100	2	M 12x1,5 x 110	14 mm	-	14	9	2,0	0,5
8006190	1.15/1	130	140	3	M 14x1,5 x 140	17 mm	-	18	11	2,0	1,2
8006350	1.15/2	200	210	7.5	M 18x1,5 x 200	25 mm	-	25	16	3,0	3,3
8006430	1.15/3	250	260	12	G 1/2 x 250	22 mm	1.06/HSP1	32	18	3,5	6,3
8006510	1.15/4	280	390	12	G 1/2 x 250	22 mm	1.06/HSP1	32	20	3,5	7,7
8006780	1.15/5	420	480	12	G 1/2 x 350	22 mm	1.06/HSP1	32	20	3,5	8,9

1.15/HSP Puller hydraulic, 3-arm pattern



- > With technical and economical benefits due to the variable clamping reach and automatic grip of the legs
- > Particularly suitable for pulling off V-belt pulleys and flywheels which are mounted on longer shafts

- > With the hydraulic spindle, a controlled and safe pulling action is possible at all times

Code	No.	a max	b	max. t	max Nm		 mm	c	d	e	
1392980	1.15/4-HSP1	280	310	10	17,0	1.06/HSP1	32 mm	32	20	3,5	8,1

1.14/L
Fan puller
2-arm pattern

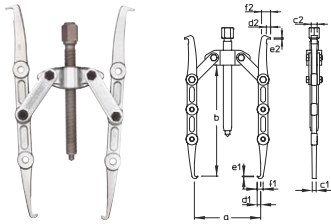

- > Especially slim hooks, can be used on both sides, with triple adjustment of the clamping depth
- > The wide or narrow hook ends, which can be used on both sides, press themselves automatically when loaded

> For use on fans with 2-holes up from Ø 10 mm

Code	No.	a max	b	max. t		mm	c1	c2	d	e1	e2	f1	f2	
8005110	1.14/1L	150	100-200	1	M 14x1,5 x 155	17 mm	6,6	10	6	1,0	2	10	16,5	0,9

1.15/L
Fan puller
3-arm pattern

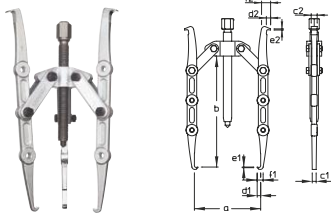

- > Especially slim hooks, can be used on both sides, with triple adjustment of the clamping depth
- > The wide or narrow hook ends, which can be used on both sides, press themselves automatically when loaded

> For use on fans with 3-holes up from Ø 10 mm

Code	No.	a max	b	max. t		mm	c1	c2	d	e1	e2	f1	f2	
8006270	1.15/1L	150	100-200	1.5	M 14x1,5 x 155	17 mm	6,6	10	6	1,0	2,0	10	16,5	1,3

1.16
Puller
2-arm pattern

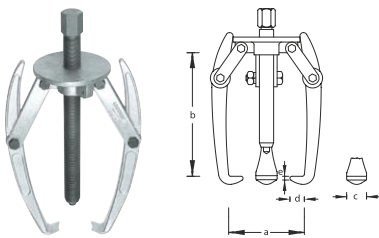

- > Very strong
- > The legs grip automatically
- > Upgradeable with hydraulic spindle

> Can be extended to 3 arms by additionally buying a large hook No. 116

Code	No.	a max	b	max. t		mm	optional	c	d	e	
8007080	1.16/1	300	300	8	G 1 x 360	36 mm	1.06/HSP3	32	19	3,0	8,4
8007160	1.16/2	450	420	8	G 1 x 500	36 mm	1.06/HSP3	32	22	3,0	10,0

1.17
Puller
3-arm pattern

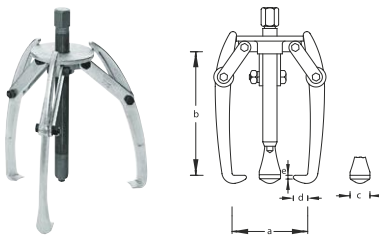

- > Very strong
- > The legs grip automatically
- > Upgradeable with hydraulic spindle

> Can be used as 2- and 3-arm puller

Code	No.	a max	b	max. t		mm	optional	c	d	e	
8007320	1.17/1	300	300	12	G 1 x 360	36 mm	1.06/HSP3	32	19	3,0	10,5
8007400	1.17/2	450	420	12	G 1 x 500	36 mm	1.06/HSP3	32	22	3,0	12,7

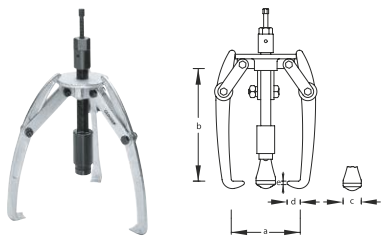

Puller

1.17/HSP
Puller
3-arm pattern



- > Very strong
- > The legs grip automatically



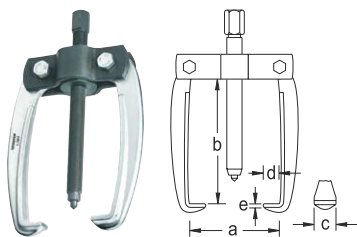

- > With the hydraulic spindle, a controlled and safe pulling action is possible at all times

Code	No.	a max	b	max. t	max Nm			c	d	e	
8014370	1.17/2-HSP3	450	295	12	29,0	1.06/HSP3	41 mm	32	22	3,0	12,6

1.18
Puller
2-arm pattern





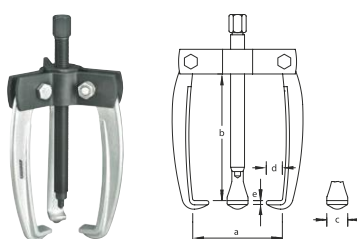

- > The tried and tested range for economical bearing removal

Code	No.	a max	b	max. t				c	d	e	
1464965	1.18/1	110	110	2	M 14x1,5 x 163	17 mm	-	17	18	5,0	1,0
1464973	1.18/2	160	140	3	M 18x1,5 x 215	19 mm	-	21	20	6,5	2,1
1464981	1.18/3	200	200	5	G 1/2 x 282	22 mm	1.06/HSP1	22	22	7,5	3,4

1.19
Puller
3-arm pattern



- > The tried and tested range for economical bearing removal

Code	No.	a max	b	max. t				c	d	e	
1465007	1.19/1	110	110	2	M 14x1,5 x 163	17 mm	-	17	18	5,0	1,4
1465015	1.19/2	160	140	3	M 18x1,5 x 215	19 mm	-	21	20	6,5	2,7
1465023	1.19/3	200	200	5	G 1/2 x 282	22 mm	1.06/HSP1	22	22	7,5	4,5

WWW.GEDORE.COM

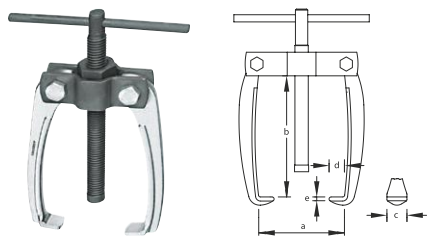

1.18

Battery-terminal puller
2-arm pattern



> The tried and tested range for economical bearing removal

> Can also be used with sliding hammer No. 1.35/1A

Code	No.	a max	b	max. t		c	d	e	
1656996	1.18/02	65	50	1	M 10 x 115	12	10	3,0	0,2
1657089	1.18/01	70	70	1	M 10 x 115	12	10	3,0	0,2
1656937	1.18/0	80	80	1	M 10 x 115	12	10	3,0	0,2



1.19

Battery-terminal puller
3-arm pattern



> The tried and tested range for economical bearing removal

> Can also be used with sliding hammer No. 1.35/1A

Code	No.	a max	b	max. t		c	d	e	
1657054	1.19/02	65	50	1	M 10 x 115	12	10	3,0	0,3
1657046	1.19/01	70	70	1	M 10 x 115	12	10	3,0	0,3
1657011	1.19/0	80	80	1	M 10 x 115	12	10	3,0	0,3

1.18/XS

Puller
2-arm pattern, with extra slim legs

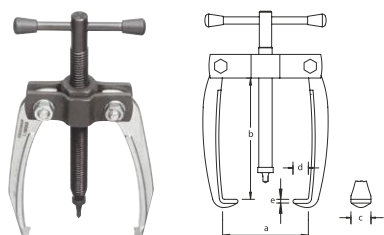

> Very slim forged legs
> Particularly suitable for space conditions that are difficult to access, e.g. in the electric motor area

Code	No.	a max	b	max. t		c	d	e	s	
2018594	1.18/OXS	50	70	0.5	M 10x1,5 x 100	8	3	2,0	2,9	0,2

1.19/XS

Puller
3-arm pattern, with extra slim legs

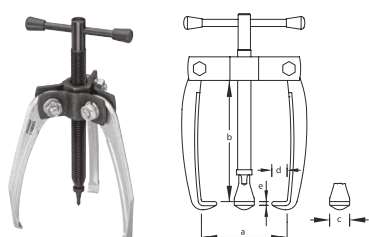

> Very slim forged legs
> Particularly suitable for space conditions that are difficult to access, e.g. in the electric motor area

Code	No.	a max	b	max. t		c	d	e	s	
2018608	1.19/OXS	50	70	0.8	M 10x1,5 x 100	8	3	2,0	2,9	0,3

Puller

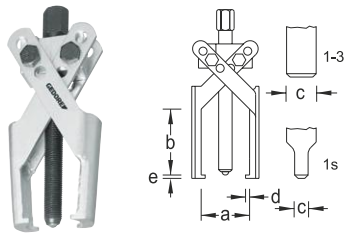

1.23

Puller
with slim legs



- > For extraction from the bearing in spaces that are difficult to access
- > The legs grip automatically

> No. 1.23/S: Especially narrow hooks

Code	No.	a1	b	max. t			c	d	e	
8084580	1.23/1S	80	85	1.5	M 10 x 105	12 mm	11	4	2,5	0,4
8084310	1.23/1	80	85	2	M 10 x 105	12 mm	23	4	2,5	0,4
8084660	1.23/2	120	120	3.5	M 14x1,5 x 130	17 mm	31	5	3,5	0,8
8084740	1.23/3	120	150	3.5	M 14x1,5 x 205	17 mm	31	5	3,5	1,0

1.23/XS

Puller
with extra slim legs

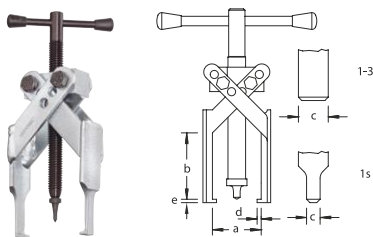

- > Very slim forged legs
- > Particularly suitable for space conditions that are difficult to access, e.g. in the electric motor area

> The legs grip automatically

Code	No.	a max	b	max. t		c	d	e	s	
2018578	1.23/1XS	80	85	0.7	M 10x1,5 x 100	9	3,5	2,0	2,9	0,4



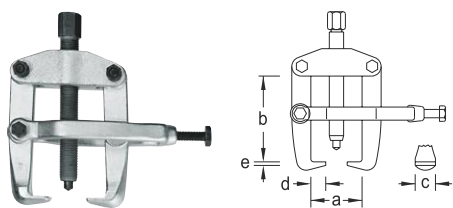

1.20

Puller
with clamping yoke



- > This puller is mainly used for pulling steering levers on cars and trucks

> The clamping yoke applies firm pressure behind the part to be moved and keeps the puller firmly in the correct position

Code	No.	a1	b	max. t				c	d	e	
8008050	1.20/1	90	85	5	M 18x1,5 x 130	19 mm	-	22	12	3,0	1,6
8008130	1.20/2	90	100	5	M 18x1,5 x 130	19 mm	-	24	15	3,0	1,7
8008210	1.20/3	150	140	7.5	G 1/2 x 175	22 mm	1.06/HSP1	30	18	3,5	3,4

1.50
Hydraulic
implements



- > Suitable for pressing, straightening, lifting, bending, and pulling
- > Consisting of hand pump No. 1.50/1 and hydraulic cylinder No. 1.51
- > Simple oil filling, can be used directly

Code	No.	consisting of:	max. bar	
8110680	1.50/11	Hydraulic hand pump 1.50/1 Hydraulic cylinder 1.51/11	700,0	15,0

1.50/1
Hydraulic
hand pump



- > Complete with 1.50 m high-pressure hose
- > To fit hydraulic cylinder 1.51
- > Incl. fitting and dust cover
- > Simple oil filling, can be used directly

Code	No.	for hydraulic cylinder	max. bar	
8022710	1.50/1	1.51/10 1.51/11	700,0	8,3

1.51
Hydraulic cylinder

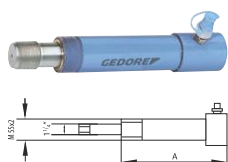

- > Connection size 3/8"
- > Incl. fitting and dust cover
- > Simple oil filling, can be used directly

Code	No.	Stroke height	max. t	max. bar	A	
8023440	1.51/10	150	10,0	700,0	275	5,0
8110760	1.51/11	230	10,0	700,0	355	6,0

1.06/H
Puller
for hydraulic implement 1.50

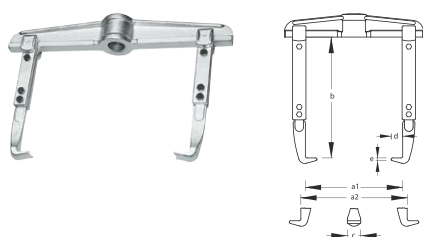

- > For the fast and damage-free removal of pulleys, wheels, ball bearings, etc.
- > Robust pattern, designed for rigidity and heavy duty use
- > Can be used as external and internal puller by repositioning the hooks

- > The reach may be increased both by using pulling legs in special lengths, and by using extensions

Code	No.	a1	a2 min	a2 max	b	max. t	c	d	e	
8112620	1.06/40	520	185	600	200	10	36	28	6,5	11,0

1.17/H
Puller
for hydraulic implement 1.50

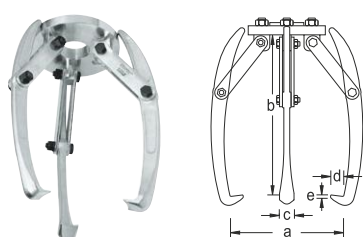

- > Heavy-duty pattern for the removal of gear wheels, spoked wheels, pulleys, etc.
- > The legs grip automatically

- > Can be used as 2- and 3-arm puller

Code	No.	a1	b	max. t	c	d	e	
8007590	1.17/10	300	300	12	36	19	3,5	9,1

i SEPARATORS

Separator pullers 1.38 and 1.40

- GEDORE separating blades are particularly suited for removing taper roller and ball bearings, inner bearing races and other tightly seated or thin-walled parts.
- To remove tightly-seated parts, the sharp edges of the separator blades are pressed behind the part to be removed which is then withdrawn using the correct 1.38 separator puller.
- To avoid damage to delicate parts, the flat surfaces of the separator blades are used. This produces a large contact surface that prevents tilting.
- The clamping reach can be enlarged with the aid of the 1.38/AV - FV tension bolt extensions.

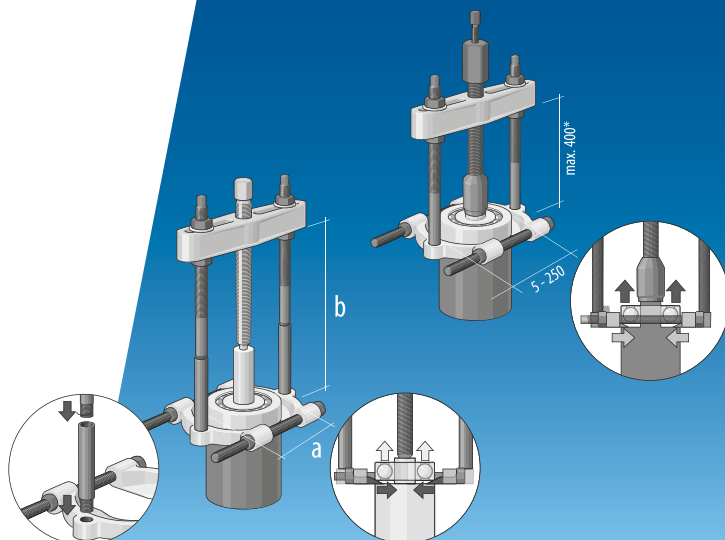



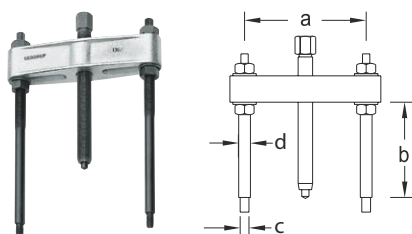

1.38 Separator puller



> These pullers are used in conjunction with the No. 1.40 cutting blades



> The tension bolts are screwed into the threaded holes of the cutting blades

Code	No.	a	b	for separator		 mm	 optional	C / D	
8017550	1.38/0	40-120	125	1.40/0	M 14 x 120	17 mm	-	M10 / M12x1,5	1,0
8017630	1.38/1	165-60	180	1.40/1	M 18 x 170	19 mm	-	M10 / M14x1,5	1,1
8017710	1.38/2	70-215	195	1.40/2	G 1/2 x 210	22 mm	1.06/HSP1	M14x1,5 / M16x1,5	3,4
8017980	1.38/3	90-300	205	1.40/3	G 3/4 x 280	27 mm	1.06/HSP2	M18x1,5 / M20x1,5	6,5
8018010	1.38/4	125-380	275	1.40/4	G 1 x 310	36 mm	1.06/HSP3	M22x1,5 / M24x1,5	11,6
8018280	1.38/5	140-440	320	1.40/5	G 1 x 360	36 mm	1.06/HSP3	M24x1,5 / M26x1,5	16,6

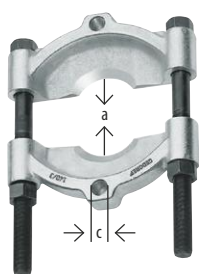
1.40 Separator





> For removing taper roller and ball bearings, inner bearing races, and other tightly-seated or thin-walled parts

Code	No.	a mm 	for puller	c	
8019680	1.40/0	5-60 mm	1.38/0	M10	0,5
8019760	1.40/1	12-75 mm	1.38/1	M10	0,9
8019840	1.40/2	22-115 mm	1.38/2	M14x1,5	2,4
8019920	1.40/3	30-155 mm	1.38/3	M18x1,5	4,7
8020180	1.40/4	30-200 mm	1.38/4	M22x1,5	8,9
8020260	1.40/5	30-250 mm	1.38/5	M24x1,5	15,3

1.38/V Extension (pair)



> Extensions for the puller No. 1.38

Code	No.	for separator	C	l mm 	
8018440	1.38/AV	1.38/0 1.38/1	M10	100	0,3
8018520	1.38/CV	1.38/2	M14x1,5	100	0,3
8018600	1.38/DV	1.38/3	M18x1,5	100	0,7
8018790	1.38/EV	1.38/4	M22x1,5	200	2,1
8018870	1.38/FV	1.38/5	M24x1,5	200	2,7

1.41
Separator and puller set

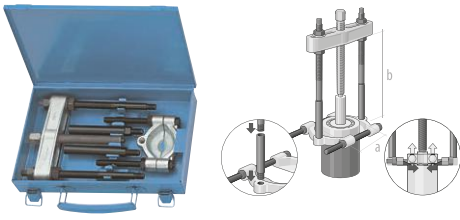

> Set comprising separator, puller, and extension rods

> In robust sheet metal case

Code	No.	a	b	Contents	
8109750	1.41/0	5-60	225	1.38/0 Extractor 40-120 mm, 1.38/AV Extension M10 (pair) 1.40/0 Separating device 5-60 mm, 141/099B Sheet metal box empty	2,8
8109830	1.41/1	12-75	280	1.38/1 Extractor 60-165 mm, 1.38/AV Extension M10 (pair) 1.40/1 Separating device 12-75 mm, 141/099B Sheet metal box empty	5,2
8109910	1.41/2	22-115	295	1.38/2 Extractor 70-215 mm, 1.38/CV Extension M14x1,5 (pair) 1.40/2 Separating device 22-115 mm, 141/299B Sheet metal box empty	9,0
8110090	1.41/3	30-155	305	1.38/3 Pulling device 90-300 mm, 1.38/DV Extension M18x1.5 (pair) 1.40/3 Separating device 30-155 mm, 141/399B Sheet metal box empty	16,0
8110170	1.41/4	30-200	475	1.38/4 Extractor 125-380 mm, 1.38/EV Extension M22x1.5 (pair) 1.40/4 Separating device 30-200 mm, 141/499B Sheet metal box empty	28,6

i 1.92

Better solutions through innovative and precise technology

Suitable for more than 40 standard ball bearings up to 6311

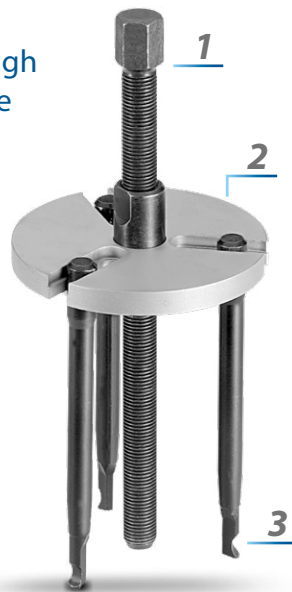

- 1** The innovative design with its maximum level of functionality in connection with simple handling provides a PLUS in effectivity and productivity.
- 2** The top plate is easy to use. The legs are fixed in the slot.
- 3** The self-locking system guarantees 100% force transmission and the maximum safety during withdrawal

- The solution for ball bearings, which are mounted on a shaft or in a housing, and thus cannot be extracted neither from the inside nor from the outside. Fields of application Suitable for more than 40 standard ball bearings up to 6311
- Extracting without drilling open the ball bearing! Therefore no risk of any chippings in machines.
- In view of the different ball bearing constructions dependent on manufacturer, the table presented can only serve as an orientation guide in selecting the legs and heads.
- The puller legs suggested in the tables are not mandatory. They only represent a recommendation based on the specifications of reputable ball bearing manufacturers

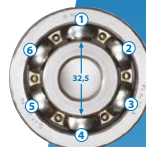

6 balls



7 balls

- The "inner functioning" (cage, diameters of the rolling elements and their number) of a bearing is not standardized.
- If a hook does not fit, then choose the next larger / smaller hook.
- Head sectioning is based on the number of rolling elements.
- In practise this means that whilst a puller leg fits into bearing 6403 of manufacturer X, it does not with the same 6403 bearing of manufacturer Y. This is because manufacturer Y installs one ball more than manufacturer X.

1.92

Set of ball bearing extractors PLUS



- > Using the GEDORE ball bearing extractor, the removal of shaft-mounted ball bearings in a housing is now possible without any problems
- > This tool is easy to use: The legs are fixed in the slot
- > Self-locking guarantees 100% power transmission and maximum safety when pulling

- > Secure at all times against slipping off - and a straight pulling force for precise working
- > Suitable for more than 40 standard ball bearings up to 6311

Code	No.	Bearing	Hook	Head size				
1553534	1.92/1	6000	1.92/10	192/1-7	2,3			
		6001	1.92/10	192/1-4				
		6002	1.92/10	192/1-3				
		6003	1.92/10	192/1-4				
		6004	1.92/30	192/1-3				
		6005	1.92/30	192/1-3				
		6006	1.92/30	192/1-3				
		6007	1.92/40	192/1-3				
		6008	1.92/40	192/1-3				
		6009	1.92/40	192/1-3				
		6010	1.92/40	192/1-3				
		6200	1.92/10	192/1-4				
		6201	1.92/20	192/1-7				
		6202	1.92/20	192/1-4				
		6203	1.92/30	192/1-4				
		6204	1.92/40	192/1-4				
		6205	1.92/40	192/1-3				
		6300	1.92/30	192/1-3				
		6301	1.92/40	192/1-3				
		6302	1.92/40	192/1-7				
		6303	1.92/40	192/1-7				
		6304	1.92/40	192/1-7				
		1553542	1.92/2	6011		1.92/50	192/2-3	5,2
				6012		1.92/50	192/2-3	
6206	1.92/50			192/2-3				
6207	1.92/50			192/2-3				
6208	1.92/60			192/2-3				
6209	1.92/60			192/2-3				
6210	1.92/60			192/2-3				
6211	1.92/60			192/2-3				
6212	1.92/70			192/2-3				
6305	1.92/60			192/2-7				
6306	1.92/60			192/2-4				
6307	1.92/60			192/2-4				
6308	1.92/70			192/2-4				
6309	1.92/70			192/2-4				
6310**	1.92/70			192/2-4				
6311***	1.92/70			192/2-4				
6403	1.92/60			192/2-3				
6404	1.92/70			192/2-3				
6405	1.92/70			192/2-7				
6406	1.92/70			192/2-7				
6407*	1.92/60			192/2-7				
1553550	1.92/12			Contents sets 1.92/1 and 1.92/2			7,6	

1.92

Parts
4 pieces



- > Pull-off hooks No. 1.92/10 to 1.92/70 = set of 4 pcs.

- > For spindle 1.1406200 please also order adapter 192/A-2!

Code	No.	Designation	
1574485	E-192/1-3	Head, small (division of 3)	0,2
1574493	E-192/1-4	Head, small (division by 4)	0,2
1574507	E-192/1-7	Head, small (division of 7)	0,2
1574515	E-192/2-3	Head, large (division of 3)	0,8
1574523	E-192/2-4	Head, large (division by 4)	0,8
1574531	E-192/2-7	Head, large (division of 7)	0,8
1574566	E-192/A-2	Adaptor for spindle large 1.92/2	0,1
1583263	1.92/10	Set of pulling legs 120 mm	0,2
1583271	1.92/20	Set of pulling legs 125 mm	0,2
1583298	1.92/30	Set of pulling legs 130 mm	0,2
1583301	1.92/40	Set of pulling legs 135 mm	0,2
1583328	1.92/50	Set of pulling legs 140 mm	0,3
1583336	1.92/60	Set of pulling legs 145 mm	0,3
1583344	1.92/70	Set of pulling legs 150 mm	0,5
1576208	1.1006170	Spindle small for 1.92/1 (M10x1,5x170mm)	0,1
1576224	1.1406200	Spindel large for 1.92/2 (M14x1,5x200mm)	0,3

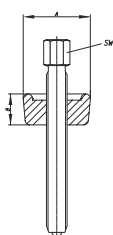

1.29

Ball bearing extractor





- › For removing ball bearings that are both on a shaft and in a housing
- › The support rings supplied for the ball bearings to be removed are placed on the bearings' inner races

- › The support rings supplied for the respective ball bearings are placed on the bearing inner ring
- › The head with spindle is then placed on the centering depression of the shaft and the spindle put under tension with the legs

Code	No.	for leg	A	B			
8011000	1.29/1	1.29/10-35	28	20	M 10 x 160	14 mm	0,2
8011270	1.29/3	1.29/25-40	40	28	M 14 x 210	17 mm	0,6
8011350	1.29/4	1.29/35-45	50	30	M 18 x 230	19 mm	0,9
8011430	1.29/5	1.29/45	65	30	M 20 x 235	22 mm	1,9

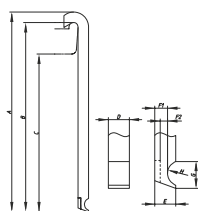
1.29

Pulling leg-Set
4 pieces

Code	No.	for ball bearing No.	for ball bearing puller	A	B	C	D	E	F1	F2	G	H	
8011510	1.29/10	6000 6001 6002 6003 6200	1.29/1	145	141	121	4,5	4	2,5	2,5	7,7	4	0,6
8011780	1.29/15	6004 6005 6006 6201 6202 6300	1.29/1	145	140	120	5,7	5	3,0	3	8,8		0,1
8011940	1.29/25	6204 6205 6301 6302 6007 6008 6300 6301 6302	1.29/1	176	170	150	6,7	6	3,7	3,7	9,8	4	0,2
			1.29/3			142							
8012080	1.29/30	6303 6304 6009 6010 6011 6012 6204 6205 6206 6303 6304 6009 6010	1.29/1	186	179	159	7,9	7	4,4 - 6,1	4,4	10,3	5	0,3
			1.29/3			151							
			1.29/4			149							
8012160	1.29/35	6305 6207 6305 6403 6011 6012	1.29/1	186	178	158	9,0	8	4,8 - 7,3	4,8	11,8	5	0,3
			1.29/3			150							
			1.29/4			148							
			1.29/5			148							
8012240	1.29/40	6303 6307 6404 6208 6209 6210 6307	1.29/3	237	227	199	11,3	10	6,4 - 8,9	6,4	13,1	6	0,6
			1.29/4			197							
8110250	1.29/45	6211 6308 6309 6405 6406 6407 6211 6212 6213 6309 6310 6311	1.29/4	237	227	197	11,3	10	6,1 - 11,6	6,1	14,7	6	0,7
			1.29/5			197							

i 1.34 INTERNAL EXTRACTORS

In a class of its own due to the precision manufacturing technology

with matching counter-stays and sliding hammers



- 1** The expansion ranges have been increased, thus fewer pullers are necessary for the same overall expansion range.
- 2** Because of their titanium nitrided coating the surfaces have increased hardness and are provided with better protection.
- 3** Force transmission is increased and improved by precise manufacturing accuracy.
- 4** The simple handling method guarantees the fast and uncomplicated withdrawal of ball bearings.

1.34/1 - 1.34/4 Internal extractor



- > To be used with slide hammer No. 1.35/0 or counter support No. 1.36/1
- > Multiple wrench size (11 + 13 mm)

Code	No.	Ø mm	M	kg
1638556	1.34/1	5,0-8,5	M10	0,1
1638564	1.34/2	8,0-15,0	M10	0,1
1638572	1.34/3	15,0-25,0	M10	0,1
1638580	1.34/4	25,0-36,0	M10	0,1

1.34/10 Internal extractor set 5 pieces

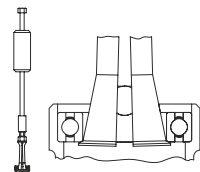

- > For close-fitting ball bearings, rings, bushings and Simmerrings®
- > Multiple wrench size (11 + 13 mm)
- > M10 connecting thread

Code	No.	Contents	Pieces	kg
1638629	1.34/10	1.34/1 internal extractor 5-8.5 mm 1.34/2 internal extractor 8-15 mm 1.34/3 internal extractor 15-25 mm 1.34/4 internal extractor 25-36 mm 1.35/0 Sliding hammer 230 mm, 200 g 134/099 Plastic case with foam insert	5	1,3

1.30/0-9 Internal extractor



- > For extremely-tightly-packed ball bearings, bearing races, bushings, and shaft seals Simmering®

- > Can be used with either sliding hammer or counter-support brace

Code	No.	Ø mm	M	mm	Slide Hammer	kg
8012750	1.30/0	5-8	M10	10 mm	1.36/1 1.35/1A	0,1
8012830	1.30/1	8-12	M10	10 mm	1.36/1 1.35/1A	0,1
8012910	1.30/2	12-15	M10	10 mm	1.36/1 1.35/1A	0,1

Code	No.	○ mm	▨ M	● mm	⌈⌋	Slide Hammer	⚖ kg
8013130	1.30/3	15-19	M10	13 mm	1.36/1	1.35/1A	0,2
8013480	1.30/4	19-25	M10	13 mm	1.36/1	1.35/2	0,2
8013560	1.30/4A	25-30	M10	13 mm	1.36/1	1.35/2	0,3
8013640	1.30/5	30-35	M10	13 mm	1.36/1	1.35/2	0,4
8013720	1.30/6	35-45	M14x1,5	17 mm	1.36/2	1.35/2	0,7
8013800	1.30/7	45-55	M14x1,5	17 mm	1.36/2	1.35/3	0,8
8013990	1.30/8	55-70	M14x1,5	19 mm	1.36/3	1.35/3	1,8
8014020	1.30/9	70-100	M14x1,5	27 mm	1.36/3	1.35/3	3,0

1.30/N

Needle bearing extractor
with reinforced shoulder



> Especially suitable for the safe and trouble-free extraction of needle roller bearings, ball bearings and brass sleeves from crankshafts

Note:

> The shoulder of the shell jaw must be applied behind the bearing

Code	No.	○ mm	▨ M	● mm	⚖ kg
8013050	1.30/2N	12-14	M10	10 mm	0,2
8013210	1.30/3N	14-19	M10	13 mm	0,2

1.30/10

Internal extractor

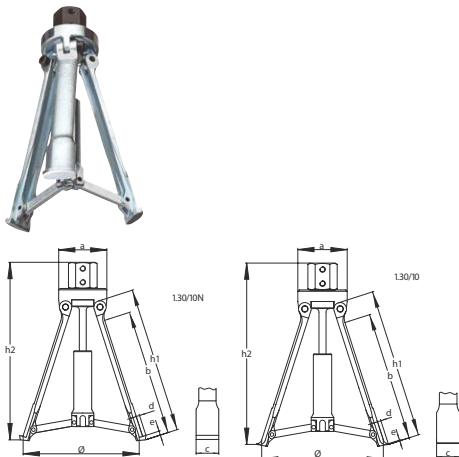

> Suitable for removing large ball bearings and bearing outer races



1.30/10N

> Both internal extractors can be used with the slide hammer 1.35/3



1.30/10

Code	No.	○ mm	▨ M	⌈⌋	● mm	a	b	c	d	e	h1	h2	⚖ kg
2724804	1.30/10N	60-160	G 1/2"	1.36/4 1.35/3	36 mm	70,0	192	33	5	6,0	213	70	2,3
8014100	1.30/10	60-160	G 1/2"	1.36/4 1.35/3	36 mm	70,0	192	33	5	1,0	213	70	2,3

1.35

Sliding hammer



> Suited for the removal of small ball bearings since there is often not enough room for counter-support braces

> Can also be used with threaded inserts No. 1.81

Code	No.	for internal extractors	▨ M	Adaptor	● mm	⌈ mm ⌋	Sliding surface	Impact weight in g	⚖ kg
1958062	1.35/0	1.34/1 - 1.34/4	M10		13	230	160	200 g	0,4
8016070	1.35/1	1.30/0 - 1.30/5 1.34/1 - 1.34/4	M10		13	270	200	200 g	0,5
1958070	1.35/1A	1.30/0 - 1.30/7	M10	M14x1,5	13	270	200	700 g	1,0
8039010	1.35/2	1.30/0 - 1.30/9	M14x1,5	M10	24	520	340	1700 g	3,0
1958089	1.35/3	1.30/6 - 1.30/10	M14x1,5		24	620	440	3000 g	4,2

1.36
Counter-support brace



Operation:

- > The counter-support brace is placed on the housing and the spindle screwed onto the spindle of the internal extractor. The toggle is held firmly, and the bearing extracted by tightening the nut.

Code	No.	for internal extractors	M	mm	kg
8016580	1.36/1	1.30/0 - 1.30/5 1.34/1 - 1.34/4	M10	27 mm	0,8
8016660	1.36/2	1.30/6 - 1.30/7	M14x1,5	32 mm	1,7
8016740	1.36/3	1.30/8 - 1.30/9	M14x1,5	32 mm	3,0
8016820	1.36/4	1.30/10	G 1/2"	36 mm	7,6

1.37
Cylinder liner puller
complete with support brace



- > Wet heavy-vehicle (e.g. Mercedes Benz, MAN) cylinder liners, automobile and stationary-engine liners, and other parts may be extracted using this puller

Code	No.	mm	M	mm	kg
8017200	1.37/2	60 - 160 mm	G 1/2"	36	6,8

1.31
Internal extractor set



1.31/0

- > Sets comprise the most used extractor sizes for the removal of ball bearings, bearing races, bushings, shaft seals, etc.

- > In robust sheet metal case



1.31/2

Code	No.	Contents	kg
8014530	1.31/0	1.30/2 Internal extractor 12-15 mm 1.30/3 Internal extractor 15-19 mm 1.30/4 Internal extractor 19-25 mm 1.30/4A Internal extractor 25-30 mm 1.36/1 Counter support for 1.30/0 - 1.30/5 131/099B Sheet metal box empty	2,6
8014610	1.31/1	1.30/2 Internal extractor 12-15 mm 1.30/3 Internal extractor 15-19 mm 1.30/4 Internal extractor 19-25 mm 1.30/4A Internal extractor 25-30 mm 1.30/5 Internal extractors 30-35 mm 1.30/6 Internal extractor 35-45 mm 1.36/1 Counter support for 1.30/0 - 1.30/5 1.36/2 Counter support for 1.30/6 - 1.30/7 131/199B Sheet metal box empty	6,4
8014880	1.31/2	1.30/2 Internal extractor 12-15 mm 1.30/3 Internal extractor 15-19 mm 1.30/4 Internal extractor 19-25 mm 1.30/4A Internal extractor 25-30 mm 1.30/5 Internal extractors 30-35 mm 1.30/6 Internal extractor 35-45 mm 1.30/7 Internal extractor 45-55 mm 1.30/8 Internal extractor 55-70 mm 1.36/1 Counter support for 1.30/0 - 1.30/5 1.36/2 Counter support for 1.30/6 - 1.30/7 131/299B Sheet metal box empty	9,2

1.32/1-2

Set of internal and external extractors



1.32/1

> Sets with internal extractors, counter supports, puller chucks, external extractors and stud extractors



1.32/2

> In robust sheet metal case



1.32/2

Code	No.	Contents	
8015260	1.32/1	1.30/2 Internal extractor 12-15 mm 1.30/3 Internal extractor 15-19 mm 1.30/4 Internal extractor 19-25 mm 1.30/4A Internal extractor 25-30 mm 1.30/5 Internal extractors 30-35 mm 1.30/6 Internal extractor 35-45 mm 1.36/1 Counter support for 1.30/0 - 1.30/5 1.36/2 Counter support for 1.30/6 - 1.30/7 1.19/OXS Puller 3-arm XS hook 50x70 mm 1.12/02 Pole terminal puller 2-arm 60x40 mm 1.06/1 Universal puller 2-arm 90x100 mm 132/199B Sheet metal box empty	10,4
8015340	1.32/2	1.30/2 Internal extractor 12-15 mm 1.30/3 Internal extractor 15-19 mm 1.30/4 Internal extractor 19-25 mm 1.30/4A Internal extractor 25-30 mm 1.30/5 Internal extractors 30-35 mm 1.30/6 Internal extractor 35-45 mm 1.30/7 Internal extractor 45-55 mm 1.30/8 Internal extractor 55-70 mm 1.36/1 Counter support for 1.30/0 - 1.30/5 1.36/2 Counter support for 1.30/6 - 1.30/7 1.19/OXS Puller 3-arm XS hook 50x70 mm 1.12/02 Pole terminal puller 2-arm 60x40 mm 1.06/1 Universal puller 2-arm 90x100 mm 1.06/2 Universal puller 2-arm 160x150 mm 1.28/1 Stud extractor 6-13 mm 132/299B Sheet metal box empty	19,0

1.61

Wheel-hub puller for automobile + trucks



- > For bolt circle diameter up to 250 mm, from Ø 100 mm with 4 holes, from Ø 120 mm with 5 holes
- > With wheel stud protection using rotating nut apertures that always lie flat to the hub for Ø 22 mm and suitable reduction bushing Ø 14 and 18 mm
- > Upgradeable with hydraulic spindle No. 1.06/HSP2





Code	No.	Number of hooks		optional	
8025300	1.61/5	5	G 3/4 x 200	1.06/HSP2	5,8

Code	No.	Designation	
8111220	1.61/H	Spare hook	0,6

1.62
Wheel-hub puller
for trucks



- > For wheel stud circles from 150 up to 350 mm
- > With wheel stud protection using rotating nut apertures that always lie flat to the hub for Ø 22 mm and suitable reduction bushing Ø 14 and 18 mm
- > This tool may also be used with the hydraulic aid Nr. 1.50 without requiring a reduction bushing
- > Upgradeable with hydraulic spindle No. 1.06/HSP3



Code	No.	Number of hooks			 optional	
8026030	1.62/8	8	G 1 x 310	36 mm	1.06/HSP3	12,6

Code	No.	Designation	
8111220	1.61/H	Spare hook	0,6

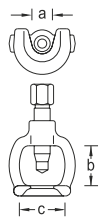
1.72
Ball joint puller





- > For the simple and damage-free removal of ball pins on track rods and push rods

Code	No.	a	b	c			
8030300	1.72/1	18	35	40	M 14x1,5 x 50	17 mm	0,3
8030490	1.72/2	23	45	50	M 14x1,5 x 50	17 mm	0,4
8030570	1.72/3	27	56	60	M 18x1,5 x 80	19 mm	0,7
8030650	1.72/4	37	78	75	G 1/2 x 110	22 mm	1,7
2183323	1.72/4A	40	80	80	G 1/2 x 140	22 mm	2,2
2183331	1.72/5A	46	100	90	G 3/4 x 160	27 mm	2,8

1.73
Universal ball joint puller





- > For pressing out the ball joint pins when removing car and truck ball joints

Code	No.	mm 	Clamping height	Fork depth	
8030810	1.73/1	23	65	24	0,7
8033240	1.73/3	32	85	28	2,5

1.74
Universal ball joint puller



- > For removing the ball joint journals on track rods, stabilizers, etc.
- > Simple operation due to slim lower part and two-stage lever adjustment

Code	No.	mm 	Clamping height	Fork depth	
8085200	1.74/1	20	12-50	35	1,4
8085390	1.74/2	20	50-80	35	1,7

1.75
Oil filter hook 3-arm
pattern



3/8" **1/2"**

- > For removing firmly seated oil filters and granulate cartridges of compressed air dryers with right-handed thread, e.g. Mercedes Benz, MAN
- > With 3/8" female square drive and adaptor 17 mm external

Code	No.	mm	
8117420	1.75/1	60-120	0,7

1.76/1
Cartridge spanner
3-arm pattern



12,5 **1/2"**

- > Especially suitable for loosening stuck granulate cartridges of compressed air dryers on trucks, with right-hand or left-hand thread
- > Great clamping reach (from 95 to 165 mm)
- > The GEDORE cartridge spanner is also usable as oil filter key
- > 1/2" square drive

Code	No.	mm	
1523651	1.76/1	95-165	1,5

1.64
Drive shaft puller



- > Suitable for drive shafts with 4 or 5 apertures
- > For wheel stud circles 100-155 mm with 6 mm screws
- > For tapped holes up to max. M14

Code	No.	Ø	
8026700	1.64/1	100 - 155 mm	4,5

1.68
Steering-wheel pullers



- > Featuring 1 pulling ring each with 100 mm and 150 mm diameter for 3-spoke and 4-spoke steering wheels
- > The pull rings are provided with sliding rubber sleeves to protect the steering wheel

Code	No.	Leg length			
8028750	1.68/1	120 mm	M 18 x 170	19 mm	2,0

1.70
Dismantling and assembly fork

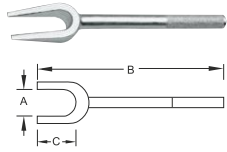

- > For fast removal of track rod and push rod ends, steering arms, and other steering parts
- > Also suitable for removing shock absorbers and other separating and dismantling work
- > The forks are suitable for use in the most confined spaces
- > Hammer blows on the handle ends are used to separate the parts

Code	No.	A	B	C	
8029210	1.70/1	18	340	80	0,8
8029480	1.70/2	23	340	80	0,9
8029560	1.70/3	29	350	90	1,1
8029640	1.70/4	40	350	90	1,2
8085040	1.70/5	45	355	95	1,2

1.78/S
Universal coil spring compressor

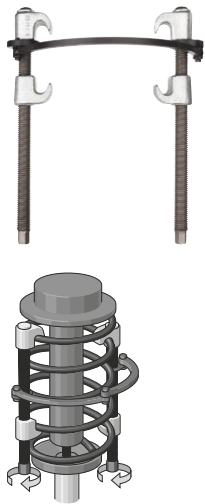

- > For the safe installation and removal of coil springs with a diameter of 110-180 mm

Safety note:

- > When the spindles are tightened evenly, the expansion chucks settle on the spring coils, so that lateral displacement is ruled out
- > VPA GS Tested safety
- > With safety bar 1 piece

Code	No.	Clamping reach	
8031380	1.78/S2	240 mm	2,2
8031460	1.78/S3	340 mm	2,6

1.78/P
Universal coil spring compressor



- > For MacPherson suspension strut and transverse link axles with spring diameters of 110-180 mm
- > The wide support rests are matched to the coil spring pitch
- > VPA GS Tested safety
- > With safety bar 2 parts
- > Version PK = hook plastic coated

Code	No.	Clamping reach	max. t	
8111300	1.78/P1	240 mm	3,5	2,6
8031030	1.78/PK1	240 mm	3,5	2,5

1.79
Spring spreader



- > For VAG exhaust installations, where the pipe is not held by bolts to the exhaust manifold, but clamped on using springs

Code	No.	
8112540	1.79/1	0,4

1.91

Tyre removing tool



- › For releasing stuck truck tyres

Code	No.	L	
8032270	1.91	300	2,0

1.26

Nut splitter



- › For splitting jammed or stripped nuts without damaging the bolt thread
- › For nuts up to property class 6
- › With chisel stopper

Code	No.	for nuts of size		mm	
8009880	1.26/1	M6 - M10		17	0,3
8009610	1.26/2	M10 - M16		17	0,3
8010030	1.26/3	M16 - M24		24	1,1

Code	No.	Designation	
2017016	1.26/M1	Spare chisel for 1.26/1 + /2	0,1
2017024	1.26/M3	Spare chisel for 1.26/3	0,1

1.26/K

Nut splitter set



- › For nuts from size 10 mm (M6) to size 36 mm (M24), including spare chisel
- › With chisel stopper
- › In robust plastic case with Check-Tool insert, Dimensions 275 x 229 x 83 mm

Code	No.	Contents	
2017008	1.26/K-3	1 nut splitter 10-17 mm, M6-M10, No. 1.26/1 1 nut splitter 17-24 mm, M10-M16, No. 1.26/2 1 nut splitter 24-36 mm, M16-M24, No. 1.26/3 2 spare chisels for 1.26/1 + 1.26/2, No. 1.26/M1 1 spare chisel for 1.26/3, No. 1.26/M3	2,5

1.26/HYD

Nut splitter hydraulic

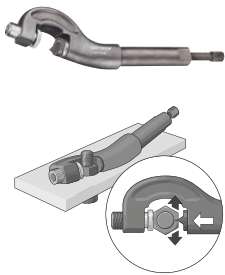

- › With strong chisel, additionally induction hardened
- › No breakout of the cutting edge
- › The chamfer at the chisel's edge improves the splitting effect and prevents breakage
- › For nuts up to property class 10
- › Chisel replaceable

Code	No.	for nuts of size		mm	max. t	
8009450	1.26/1 HYD	M4 - M14		12	5	0,8
8009530	1.26/2 HYD	M14 - M24		12	13	3,4

Code	No.	Designation	
2018586	1.26/M1 HYD	Spare chisel for 1.26/1 HYD	0,1
2043920	1.26/M2 HYD	Spare chisel for 1.26/2 HYD	0,1

1.28

Stud extractor



- › For removing damaged studs with right-hand or left-hand thread
- › Even suitable for extremely short stud ends

Code	No.	Ø-Stud		mm	
8010620	1.28/1	6-13		19	0,2
8010700	1.28/2	8-19		19	0,3
8010890	1.28/3	19-25		19	0,4
1465031	1.28/4	5-26		19	0,6

1.90
Flange separators

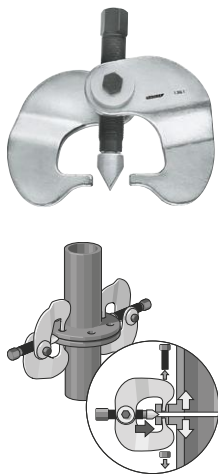

- > For separating DIN standard flanges on pipes when changing seals and doing maintenance work
- > For Ø 80-250 mm and screw threads M16-M24

Operation:

- > Always use the separators in pairs and attach them to opposite sides of the flange (180°). When the two spindles are turned alternately, the flanges will be separated from one another evenly. When the spindles are turned back alternately, this guarantees a perfect fitting of the flanges in their original position. Only use in pairs! Mutual clamping (180°)

Code	No.	Ø	for screws of size	
1596403	1.90/1	80-250	M16 - M24	5,5

1.81/1 + 2
Thread adaptor set for 1-hole uses



- > The threaded inserts make the removal of threaded caps, for example, possible, when these possess one threaded hole
- > No. 1.81/1: For slide hammer No. 1.35/1, 1.35/2, counter support No. 1.36/1
- > No. 1.81/2: For slide hammer No. 1.35/2, 1.36/2, counter support No. 1.36/3

Code	No.	Connecting thread	
1120727	1.81/1	M10 - M4 M10 - M5 M10 - M6 M10 - M8 M10 - M10 M10 - M12	0,2
1120743	1.81/2	M14x1,5 - M8 M14x1,5 - M10 M14x1,5 - M12 M14x1,5 - M14 M14x1,5 - M16 M14x1,5 - M18	0,5

1.81/10 + 20
Thread adaptor set for 1-hole and 2-hole uses, 2 each

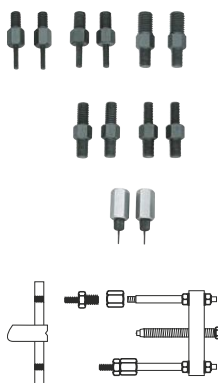

- > The threaded inserts make the removal of threaded caps, for example, possible, when these possess 1 or 2 threaded holes
- > No. 1.81/10: For puller No. 1.38/0, 1.38/1
- > No. 1.81/20: For puller No. 1.38/2

Code	No.	Connecting thread	
1120735	1.81/10	M10 - M4 M10 - M5 M10 - M6 M10 - M8 M10 - M10 M10 - M12	0,7
1120751	1.81/20	M14x1,5 - M8 M14x1,5 - M10 M14x1,5 - M12 M14x1,5 - M14 M14x1,5 - M16 M14x1,5 - M18	1,2

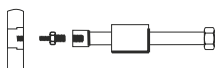
1.81/KThread adaptor set
for 1-hole uses

- > The threaded inserts make the removal of threaded caps, for example, possible, when these possess one threaded hole
- > No. 1.81/K-1: With slide hammer No. 1.35/1, bar 230 mm and impact weight 200 g
- > No. 1.81/K-12: With slide hammer No. 1.35/1A, bar 230 mm and impact weight 700 g, adaptor M14x1.5
- > In robust plastic case, 275 x 229 x 83 mm

Code	No.	Connecting thread	
1936549	1.81/K-1	M10 - M4	1,0
		M10 - M5	
		M10 - M6	
		M10 - M8	
		M10 - M10	
		M10 - M12	
1936557	1.81/K-12	M10 - M4	1,8
		M10 - M5	
		M10 - M6	
		M10 - M8	
		M10 - M10	
		M10 - M12	
		M14x1,5 - M14	
		M14x1,5 - M16	
		M14x1,5 - M18	

1.18/1.19

Puller-Set



- > This perforated panel offers place for 12 pullers of the series 1.18 and 1.19
- > For clamping depths from Ø 200 mm and clamping reach up to 200 mm

- > Delivery includes perforated panel

Code	No.	Contents	
1824007	1.18/1.19	1.18/1 Puller 2-arm 110x110 mm 1.18/2 Puller 2-arm 160x140 mm 1.18/3 Puller 2-arm 200x200 mm 1.18/02 Pole terminal remover 2-arm 65x50 mm 1.18/01 Pole terminal remover 2-arm 70x70 mm 1.18/0 Pole terminal remover 2-arm 80x80 mm 1.19/1 Puller 3-arm 110x110 mm 1.19/2 Puller 3-arm 160x140 mm 1.19/3 Puller 3-arm 200x200 mm 1.19/02 Pole terminal remover 3-arm 65x50 mm 1.19/01 Pole terminal remover 3-arm 70x70 mm 1.19/0 Pole terminal remover 3-arm 80x80 mm 1500 H 1 tool hook inclined hook end d 4 mm (12x) 1500 H 2-13 Tool clamp d 13 mm (6x) 1450 L Tool board empty, 987x493 mm	21,0

2.20

Truck workshop set
Add-on system

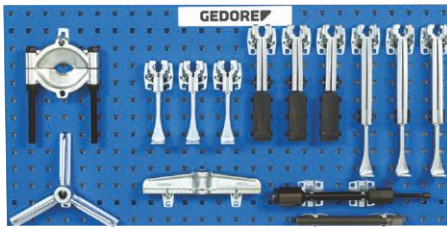

- > Clearly arranged module system
- > Using this set, you will be able to assemble 12 of the usual versions with hydraulic spindle, in seconds
- > 2-armed cross beam with adjustment scale for even adjustment of the puller hooks. Allows centric and force-optimized pulling even with highest pulling forces

> Everything at hand on perforated wall-board

Code	No.	Contents	
1088718	2.20	1 Traverse 2-arm 260 mm, No. 106/2A03 1 traverse 3-arm 260 mm, No. 107/2A03 1 spindle SW 22, G 1/2", 210 mm, No. 1.2106210 1 grease hydraulic pressure spindle 10 t, No. 1.06/HSP1 3 puller hooks 150 mm, No. 106/B-150-N 3 Pulling hooks 300 mm, No. 106/B-300-N 3 puller hooks slim 220 mm, No. 106/B-220-S 1 separating device 22-115 mm, No. 1.40/2	23,3

2.30

Industrial pulling set
Add-on system

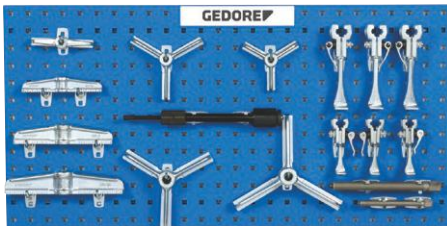

- > For the assembly of the tried and tested 1.06 and 1.07 versions
- > Using this set, you will be able to assemble 12 of the usual versions with high-speed clamping legs, including hydraulic spindle, in seconds

> Everything at hand on perforated wall-board

Code	No.	Contents	
1393014	2.30	1 2-arm traverse 140 mm, No. 106/103 1 2-arm cross-beam 180 mm, No. 106/1A03 1 2-arm cross-beam 220 mm, No. 106/203 1 cross bar 2-arm 260 mm, No. 106/2A03 1 traverse 3-arm 140 mm, No. 107/103 1 traverse 3-arm 180 mm, No. 107/1A03 1 traverse 3-arm 220 mm, No. 107/203 1 cross bar 3-arm 260 mm, No. 107/2A03 1 spindle SW 17, M14x1.5, 140 mm, No. 1.1406140 1 spindle SW 22, G 1/2", 210 mm, No. 1.2106210 1 Grease hydraulic pressure spindle 10 t, No. 1.06/HSP1 3 Quick release hooks 100 mm, No. 106/A-100-E 3 quick-release draw hooks 150 mm, No. 106/B-150-E	19,4

2.40

Pulling set for construction machines
Add-on system

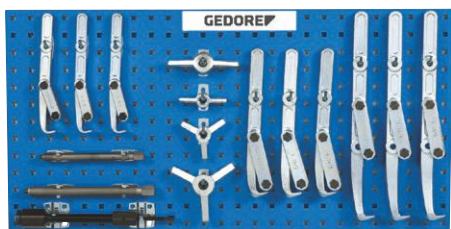

- > For the assembly of the robust and handy strap-pattern pulling tools 1.14 and 1.15
- > With this set, you will be able to assemble 10 of the usual flexible strap-pattern pulling tools from the range 1.14/1.15, including the new hydraulic spindle

- > Everything at hand on perforated wall-board

Code	No.	Contents	
1393030	2.40	1 head 2-armed, No. 114/204 1 head 2-armed, No. 114/304 1 head 3-armed, No. 115/204 1 head 3-arm, No. 115/304 1 spindle SW 19, M18x1.5, 200 mm, No. 1.1806200 1 spindle SW 22, G 1/2", 250 mm, No. 1.2106250 1 Grease hydraulic pressure spindle 10 t, No. 1.06/HSP1 3 puller hooks 210 mm, No. 114/201 3 Pulling hooks 260 mm, No. 114/301 3 puller hooks 390 mm, No. 114/401 6 lugs No. 114/208 12 lugs No. 114/308	24,3

2.50

Set of internal and external extractors



- > Suitable for various applications of external or internal extraction
- > Internal extractor for drill holes with \varnothing 5 - 55 mm. To be used with slide hammer or counter support
- > External pullers with various spans up to 130 mm for the most diverse pulling problems

- > Pulling and separating devices including extensions, ideal for pulling off tightly fitted or thin-walled parts for outside diameters 5 - 115 mm
- > Everything at hand on perforated wall-board

Code	No.	Contents	
2017040	2.50	1 internal extractor 5-8 mm, No. 1.30/0 1 internal extractor 8-12 mm, No. 1.30/1 1 internal extractor 12-15 mm, No. 1.30/2 1 internal extractor 15-19 mm, No. 1.30/3 1 internal extractor 19-25 mm, No. 1.30/4 1 Internal extractor 25-30 mm, No. 1.30/4A 1 internal extractor 30-35 mm, No. 1.30/5 1 internal extractor 35-45 mm, No. 1.30/6 1 internal extractor 45-55 mm, No. 1.30/7 1 slide hammer 230 mm, 700 g, No. 1.35/1A 1 slide hammer 500 mm, 1.7 kg, No. 1.35/2 1 counter support for 1.30/0 - 1.30/5, No. 1.36/1 1 counter support for 1.30/6 - 1.30/7, No. 1.36/2 1 universal puller HIGH POWER 2-arm 130x100 mm, No. 1.04/HP1A 1 Pole terminal puller 3-arm 70x80 mm, No. 1.13/00 1 puller with extra slim hook 80x85 mm, No. 1.23/1S 1 puller 40-120 mm, No. 1.38/0 1 puller 70-215 mm, No. 1.38/2 1 extension M10, No. 1.38/AV 1 extension M14x1.5, No. 1.38/CV 1 separating device 5-60 mm, No. 1.40/0 1 separating device 22-115 mm, No. 1.40/2	29,0